



Step by Step Guide Commander S100

Frames sizes 1 to 4



See page 8
for details



Part Number: 0478-0644-09 Issue 09

Read the User Guide



Before using this product you must read and understand the safety information within the Commander S100 User Guide at www.controltechniques.com/support



MARSHAL



Introduction

This guide provides step-by-step instructions on how to install the drive, wire the drive using appropriate fuses and cables, configure the drive and run the motor. The Commander S100 is fully compatible with the mobile app, Marshal, which can be found on Google Play store and the App Store. Download the full Commander S100 User Guide at www.controltechniques.com/support.

The drive is fitted with a terminal cover which will need to be removed to wire the drive. Re-installing the terminal cover after wiring is optional on the Commander S100.

Important safety information

1. Hazards

This Step by Step Guide applies to Commander S100 drives and supplies safety information that must be observed.

2. Responsibility

It is the responsibility of the installer to ensure the safety of the complete system. The manufacturer of the drive accepts no liability for any consequences resulting from inappropriate, negligent, or incorrect design and installation or the failure of the drive.

3. Compliance with Regulations

The installer is responsible for complying with all relevant regulations, such as national wiring regulations.

4. Enclosure

The Basic Drive Module (BDM) is open-type and must be mounted in an enclosure which prevents access except by trained and authorised personnel.

5. Electrical Hazards

The voltages used in the drive can cause severe electrical shock and/or burns and could be lethal. Care is necessary when working with or adjacent to the drive.

6. System design

System design, installation, commissioning, start-up and maintenance must be carried out by personnel with the necessary training and competence who must read all of the safety information and instructions in the User Guide.

When protected by fuses or circuit breakers with maximum ratings as specified in Table 1-4, this product is suitable for use on a circuit capable of delivering not more than 5,000 RMS symmetrical amperes, 480 V maximum (up to the rated voltage of the drive module).

Drive features

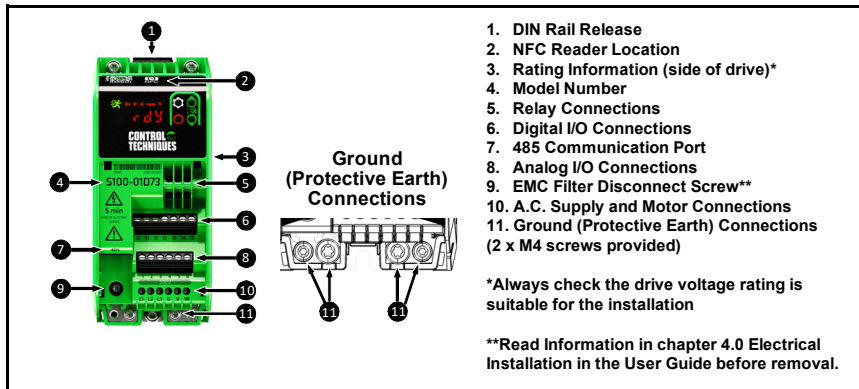

STEP 1: Mount the drive

A drill template for wall mounting is included on the drive packaging for quick installation. No screws are required when mounting the drive onto a DIN rail.

Table 1-1 Drive dimensions

Frame size	Overall Dimensions (±0.5 mm)				Mounting Dimensions (±0.5 mm)				
				Weight					Ø Mounting Hole Diameter
S100-01	156 mm 6.14 in	68 mm 2.70 in	130 mm 5.12 in	0.7 kg 1.54 lb	46 mm 1.81 in	145 mm 5.71 in	45 mm 1.77 in	22.5 mm 0.89 in	4.8 mm 0.19 in
S100-02	192 mm 7.56 in	68 mm 2.70 in	132 mm 5.20 in	0.8 kg 1.76 lb	46 mm 1.81 in	180 mm 7.11 in	45 mm 1.77 in	22.5 mm 0.89 in	4.8 mm 0.19 in
S100-03	192 mm 7.56 in	90 mm 3.54 in	132 mm 5.20 in	1 kg 2.2 lb	46 mm 1.81 in	180 mm 7.11 in	65 mm 2.56 in	37.5 mm 1.48 in	4.8 mm 0.19 in
S100-04	264 mm 10.39 in	115 mm 4.53 in	160 mm 6.30 in	4.1 kg 9.0 lb	N/A	253 mm 9.97 in	99 mm 3.90 in	99 mm 3.90 in	5.3 mm 0.21 in

	Drive Clearances	S100-01x13, S100-01x23	All other drives
	A	100 mm (3.94 in)	45 mm (1.77 in)
	B	0 mm (0 in)	

The drive should be operated in an ambient temperature range of -10 °C to 40 °C (14 °F to 104 °F). For temperatures exceeding this range output current deratings apply. For details on de-rating the drive and other environmental conditions follow the guidance in the Commander S100 User Guide.

STEP 2: Removing / installing the terminal Cover

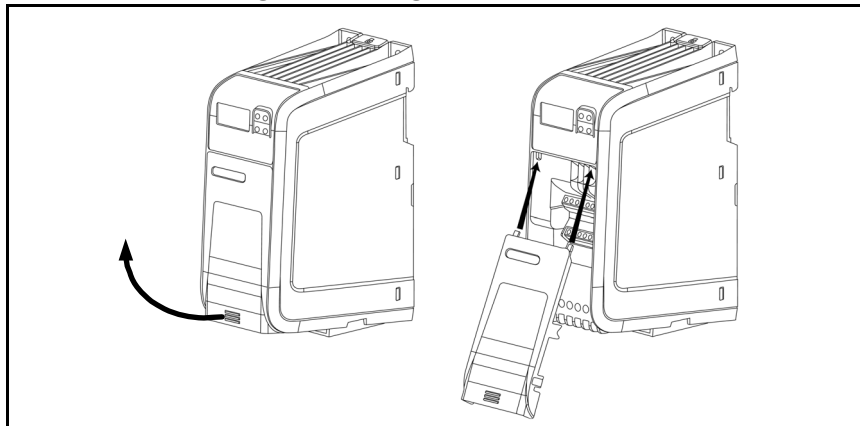

STEP 3: Wire the drive



Power Terminals (S100-034xx and S100-04xxx): 4 mm (5/32 in) flat-blade screwdriver
Power Terminals (all other models): 3 mm (1/8 in) flat-blade screwdriver
Control Terminals (all models): 3 mm (1/8 in) flat-blade screwdriver

Power connections

Connect the supply and motor connections using the cables and fuses or MCB's in Table 1-4. When using a single-phase supply, the supply should be connected to L1 and L2.

Figure 1-1 Power terminal connection

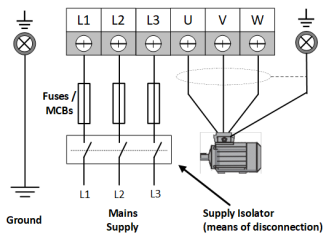

Table 1-2 Recommended Torque Settings

Drive Voltage Rating	100 V	200 V	400 V
Power Connection	0.5 Nm (4.4 lb in)		0.6 Nm (5.3 lb in)
Ground Connections	1.5 Nm (13.3 lb in)		
Control Connections	0.4 Nm (3.5 lb in)		

Always use a screened motor cable with the Commander S100 and connect this screen to the back-plate or the Cable Management Bracket accessory.

Ground connections



Ground conductor should use two copper conductors of the same cross-sectional area as the supply conductors.

To meet UL requirements, UL Listed closed-loop connectors (ring crimps) sized according to the field wiring shall be used for ground connections.

Control connections

Figure 1-2 Default Control Terminal Connections (P0.05 = 1, P0.10 = 1)

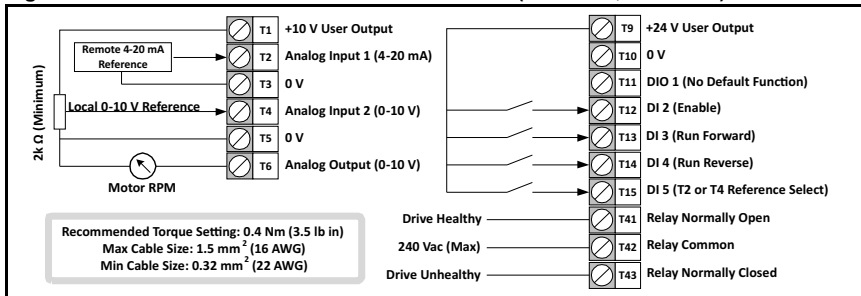

The default configuration above uses a remote 4-20 mA on analog input 1 (T2) or a local 0-10 V on analog input 2 (T4) for speed control. Select between these two references using digital input 5 (T15).

For other IO configurations see Drive Configurations in the User Guide or within **Marshal**.



The control connections shown above and the 485 port can be PELV rated when connected within a PELV circuit. The terminals are not PELV rated if the relay is connected to a circuit exceeding Overvoltage Category II.

NOTE

Voltage rating of relay cables should be suitable for the maximum expected voltage

Supply Cable, Motor Cable and Fuse/MCB Selection

Table 1-3 Fuse, MCB and Cable Compliance

Standard	IEC	UL
Fuse Class	gG	CC, J or T
MCB	Compliant with EN IEC 60947-2 are recommended, with > 5 kA short circuit breaking capacity. Type C.	The circuit breaker must be UL listed and suitable for the installation environment, rated 600 Vac with a short circuit rating > 5 kA. Type C.
Supply and Motor Cables	All cable sizes are for copper cables. IEC cable sizes assume PVC insulation, installation method B2 and ambient temperature of 40 °C (104 °F).	Cables must be copper and rated for at least 60 °C (140 °F) operation.

The voltage rating of fuses and MCBs must be greater than or equal to the highest supply voltage of the system. Cables must be provided with mechanical protection against damage and be rated for a voltage in excess of the maximum supply voltage.

Table 1-4 Fuse, MCB and Cable Selection

Model Number	Rated Current		Rated Power		Supply Phases	Max Input Current	IEC		UL		Cables for IEC60364-5-52		Cables for UL61800-5-1	
	A	kW	hp	Fuses			MCB	Fuses	MCB	Supply	Motor	Supply	Motor	
	A			A			A	A		mm ²		AWG		
100 V Drives (100 to 120 V ±10 %)														
S100-01113	1.2	0.18	0.25	1	7.2	10	10	10	15	1.5	1.5	24	24	
S100-01123	1.4	0.25	0.33	1	8.5	10	10	15	15	1.5	1.5	24	24	
S100-01133	2.2	0.37	0.5	1	10.4	12	12	15	15	1.5	1.5	22	22	
S100-03113	3.2	0.55	0.75	1	14.8	16	16	20	25	2.5	1.5	20	20	
S100-03123	4.2	0.75	1	1	20.0	25	25	30	25	2.5	1.5	18	18	
S100-03133	6	1.1	1.5	1	28.5	32	32	40	40	6††	1.5	16	16	
200 V Drives (200 to 240 V ±10 %)														
S100-01S13	1.4	0.18	0.25	1	3.3	6	6	6	15	1.5	1.5	24	24	
S100-01213	1.4	0.18	0.25	3	2.0	4	6	6	15	1.5	1.5	24	24	
S100-02S11	1.2	0.18	0.25	1	3.3	6	6	6	15	1.5	1.5	24	24	
S100-01S23	1.6	0.25	0.33	1	3.8	6	6	6	15	1.5	1.5	24	24	
S100-01223	1.6	0.25	0.33	3	2.3	4	6	6	15	1.5	1.5	24	24	
S100-02S21	1.4	0.25	0.33	1	3.8	6	6	6	15	1.5	1.5	24	24	
S100-01S33	2.4	0.37	0.5	1	4.7	6	6	6	15	1.5	1.5	22	22	
S100-01233	2.4	0.37	0.5	3	2.8	4	6	6	15	1.5	1.5	22	22	
S100-02S31	2.2	0.37	0.5	1	4.7	6	6	6	15	1.5	1.5	22	22	
S100-01S43	3.5	0.55	0.75	1	8.0	10	10	10	15	1.5	1.5	20	20	
S100-01243	3.5	0.55	0.75	3	4.7	6	6	6	15	1.5	1.5	20	20	
S100-02S41	3.2	0.55	0.75	1	8.0	10	10	10	15	1.5	1.5	20	20	
S100-01S53	4.6	0.75	1	1	9.5	12	12	15	15	1.5	1.5	18	18	
S100-01253	4.6	0.75	1	3	5.7	8	8	10	15	1.5	1.5	18	18	
S100-02S51	4.2	0.75	1	1	9.5	12	12	15	15	1.5	1.5	18	18	
S100-01D63	6.6	1.1	1.5	1	15.3	16	20	20	20	2.5†	1.5	16	16	
				3	12.2	16	16	15	15	1.5	1.5	16	16	
S100-02S61	6	1.1	1.5	1	15.3	16	20	20	20	2.5†	1.5	16	16	
S100-01D73	7.5	1.5	2	1	18.4	20	25	25	20	2.5†	1.5	16	14	
				3	14.3	16	16	20	20	2.5†	1.5	16	14	
S100-02S71	6.8	1.5	2	1	18.4	20	25	25	20	2.5†	1.5	16	14	
S100-03D13	10.6	2.2	3	1	26.1	32	32	35	30	4	1.5	14	14	
				3	19.7	25	25	25	25	4	1.5	14	14	
S100-04213	17	4	5	3	20.6	25	25	25	25	4	2.5	12	12	
S100-04223	24.2	5.5	7.5	3	26.89	32	35	35	35	6.0††	6.0††	10	10	
400 V Drives (380 to 480 V ±10 %)														
S100-02413	1.2	0.37	0.5	3	1.9	4	6	6	15	1.5	1.5	24	24	
S100-02423	1.7	0.55	0.75	3	2.5	4	6	6	15	1.5	1.5	22	22	
S100-02433	2.2	0.75	1	3	3.0	4	6	6	15	1.5	1.5	22	22	
S100-02443	3.2	1.1	1.5	3	4.5	6	6	6	15	1.5	1.5	20	20	
S100-02453	3.7	1.5	2	3	5.6	8	8	10	15	1.5	1.5	20	20	
S100-02463	5.3	2.2	3	3	8.2	10	16	15	15	1.5	1.5	18	18	
S100-03413	7.2	3	3	3	13.2	16	16	20	15	2.5	1.5	16	16	
S100-03423	8.8	4	5	3	16.0	20	20	25	20	2.5	1.5	14	14	
S100-04413	13	5.5	7.5	3	24.7	32	32	35	35	6††	2.5	10	12	
S100-04423	16	7.5	10	3	20.31	25	25	25	25	4.0	2.5	10	12	
S100-04433	23	11	15	3	26.0	32	32	35	35	6††	4.0	10	10	

Cables marked † need to be rated for 90 °C and 1.5 mm² in order to terminate with a ferrule.

Cables marked †† need to be rated for 90 °C and 4 mm² in order to terminate with a ferrule.

Integral solid state short circuit protection does not provide branch circuit protection. Branch circuit protection must be provided in accordance with the National Electrical Code and any additional local codes.

STEP 4: Run the motor

It is recommended to use the FastStart option within **Marshal** to configure the drive. Alternatively, the keypad can be used to edit drive parameters directly. For a guide to use the drive keypad, refer to Figure 1-3.



Configure																																					
Action	Detail																																				
Power	Power the drive, ensure the drive is not enabled. (Display shows: inh)																																				
Enter	<ol style="list-style-type: none"> Minimum Frequency Limit P0.01 (Hz) Maximum Frequency Limit P0.02 (Hz) Typically, the maximum frequency limit used is the motor rated frequency. <ol style="list-style-type: none"> Acceleration Rate 1 P0.03 (s) Deceleration Rate 1 P0.04 (s) These parameters define ramp times between 0 Hz and <i>Maximum Frequency Limit</i> P0.02.																																				
Select	<ol style="list-style-type: none"> Frequency Reference Configuration P0.05 This parameter configures the drive speed control. See details within Marshal or the Commander S100 User Guide .																																				
Enter Motor Nameplate Details	<ol style="list-style-type: none"> Motor Rated Current P0.06 (A) Motor Rated Speed P0.07 (rpm) Motor Rated Voltage P0.08 (V) Motor Rated Power Factor P0.09 (cosϕ) <div style="text-align: right; border: 1px solid black; padding: 5px; margin-top: 10px;"> <table border="1" style="font-size: small; border-collapse: collapse; width: 100%;"> <thead> <tr> <th colspan="6">MOT3 \checkmark LS 80 L T</th> </tr> <tr> <th colspan="6">N°734570 B1 02 kg 9</th> </tr> <tr> <th>IP55</th> <th>I cl.f</th> <th>40 °C</th> <th>S1</th> <th colspan="2"></th> </tr> <tr> <th>V</th> <th>Hz</th> <th>min⁻¹</th> <th>kW</th> <th>cosϕ</th> <th>A</th> </tr> </thead> <tbody> <tr> <td>Δ230</td> <td>50</td> <td>1480</td> <td>0.75</td> <td>0.8</td> <td>1.1</td> </tr> <tr> <td style="text-align: center;">8</td> <td style="text-align: center;">7</td> <td></td> <td style="text-align: center;">9</td> <td style="text-align: center;">6</td> <td></td> </tr> </tbody> </table> </div>	MOT3 \checkmark LS 80 L T						N°734570 B1 02 kg 9						IP55	I cl.f	40 °C	S1			V	Hz	min ⁻¹	kW	cos ϕ	A	Δ 230	50	1480	0.75	0.8	1.1	8	7		9	6	
MOT3 \checkmark LS 80 L T																																					
N°734570 B1 02 kg 9																																					
IP55	I cl.f	40 °C	S1																																		
V	Hz	min ⁻¹	kW	cos ϕ	A																																
Δ 230	50	1480	0.75	0.8	1.1																																
8	7		9	6																																	
Select	<ol style="list-style-type: none"> Enable/Run Configuration P0.10 This parameter configures how to run the drive. See details within Marshal or the Commander S100 User Guide .																																				
Running and Speed Control (Default Configuration Settings)																																					
Run	Always ensure it is safe to start the motor before doing so. Provide an Enable signal to terminal 12 (T12). Provide a run signal to T13 (Run Forward) or T14 (Run Reverse).																																				
Increasing and Decreasing Motor Speed	Increase or decrease current to Analog Input 1 (T2) to increase or decrease the frequency reference. Close Digital Input 5 (T15) to switch to a voltage reference from Analog Input 2 (T4).																																				
Stopping	Remove the Run Forward (T13) or Run Reverse (T14) signal to stop the motor by following the selected deceleration rate. If the Enable signal (T12) is removed while the motor is running, the drive output is immediately disabled, and the motor will coast to a stop.																																				
Troubleshooting																																					
Restore Factory Defaults	<ol style="list-style-type: none"> Ensure the drive is not enabled. (Display shows: inh) Set P4.01 to 1 to load 50 Hz defaults or 2 to load 60 Hz defaults. Press the settings key to exit the parameter. 																																				
Troubleshoot	If the drive detects a fault, it will display an error code. All error codes for the drive and possible resolutions are available in the mobile app, Marshal . Alternatively, please view the diagnostics section in the Commander S100 User Guide .																																				



Figure 1-3 Using the keypad

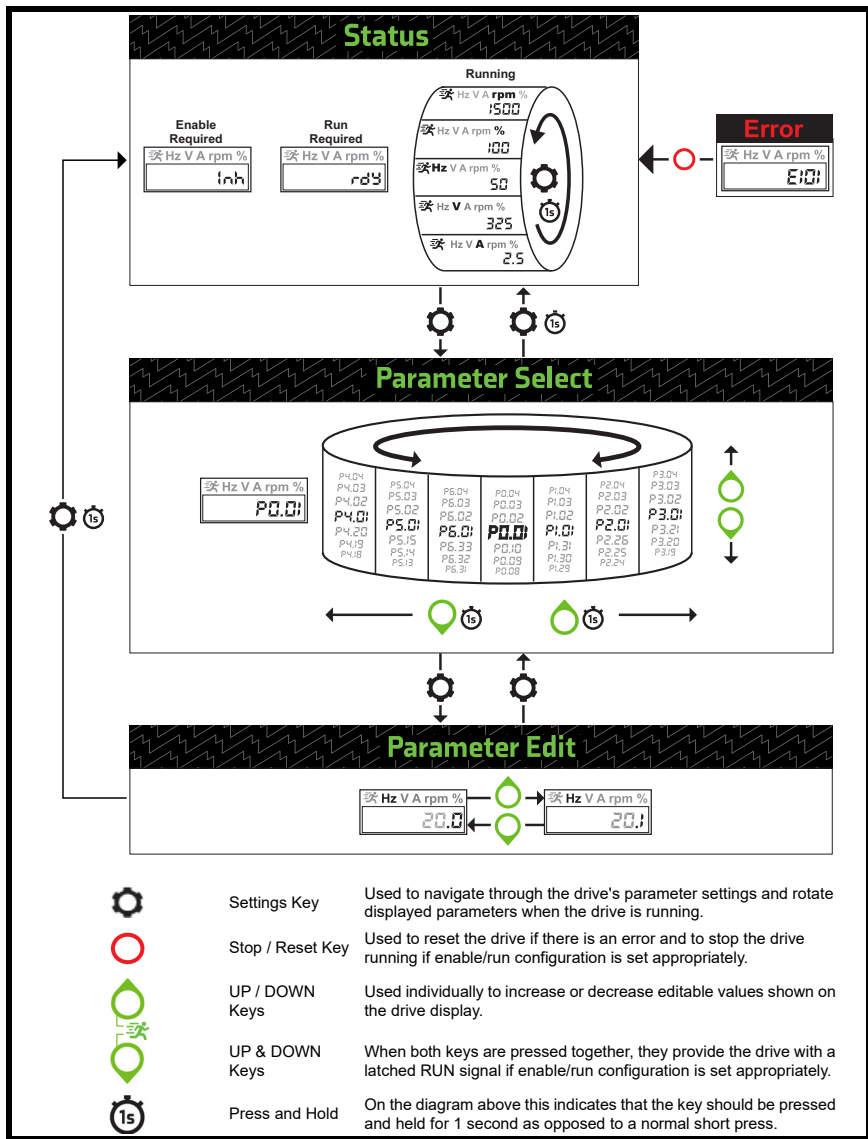



EN

Free 5-year Manufacturer's Warranty

In order to qualify for the free 5-year manufacturer's warranty, you must register your drive on www.controltechniques.com/shield within six (6) months of date of purchase. Failure to register within the specified period will mean that your drive will only benefit from the warranty given to you by the person or entity that sold the drive to you.

Warranty Terms

This offer is subject to our 5-year Warranty Terms and Conditions which can also be found on www.controltechniques.com/shield.

FR

5 ans de garantie fabricant gratuite

Afin de profiter des 5 ans de garantie fabricant gratuite, vous devez enregistrer votre variateur sur www.controltechniques.com/shield dans les six (6) mois à compter de la date d'achat. Si vous n'enregistrez pas votre produit dans le délai spécifié, il sera uniquement couvert par la garantie proposée par la personne ou l'organisme vous l'ayant vendu.

Conditions de garantie

Cette offre est soumise à nos Conditions générales de garantie sur 5 ans, également disponibles sur www.controltechniques.com/shield.

IT

5 anni di garanzia gratuita del costruttore

Per aver diritto ai 5 anni di garanzia gratuita del costruttore bisogna registrare l'azionamento sul sito www.controltechniques.com/shield entro 6 (sei) mesi dalla data di acquisto. Laddove non venisse registrato entro il termine specificato, l'azionamento sarà coperto unicamente dalla garanzia concessa dalla persona o dalla società venditrice.

Termini di garanzia

La presente offerta è soggetta ai nostri Termini e condizioni di garanzia quinquennale, consultabili anche sul sito www.controltechniques.com/shield.

DE

Kostenlose 5-jährige Herstellergarantie

Um die kostenlose 5-jährige Herstellergarantie in Anspruch nehmen zu können, müssen Sie Ihren Umrichter innerhalb von sechs (6) Monaten nach Kaufdatum unter www.controltechniques.com/shield registrieren. Wenn Sie Ihren Umrichter nicht innerhalb der angegebenen Frist registrieren, ist dieser nur durch die Gewährleistung gedeckt, die Ihnen von der Person bzw. dem Unternehmen gewährt wird, welche(s) Ihnen den Umrichter verkauft hat.

Garantiebedingungen

Diesem Angebot liegen die Bedingungen unserer 5-Jahres-Garantie zugrunde, die auch unter www.controltechniques.com/shield zu finden sind.

ES

Garantía del fabricante de 5 años gratuita

Para poder disfrutar de la garantía del fabricante de 5 años gratuita, debe registrar su accionamiento en www.controltechniques.com/shield en un plazo de seis (6) meses desde la fecha de compra. En caso de no registrarlo en el plazo especificado, el accionamiento solo estará cubierto por la garantía proporcionada por la persona o entidad que le vendió el accionamiento.

Términos de la garantía

Esta oferta está sujeta a nuestros Términos y Condiciones de la Garantía de 5 años, que puede encontrar también en www.controltechniques.com/shield.



Warning Before using this product you must read and understand the safety information within the User Guide at the URL below.	Avertissement Avant d'utiliser ce produit, il est impératif de lire et de bien comprendre les consignes de sécurité du Guide de mise en service, disponible à l'adresse ci-dessous.
Avvertenza Prima di utilizzare questo prodotto leggere e assicurarsi di aver compreso le informazioni sulla sicurezza contenute nella Guida dell'utente consultabile all'URL indicato qui sotto.	Warnung Bevor Sie dieses Produkt verwenden, müssen Sie die Sicherheitshinweise in der Betriebsanleitung unter der nachstehenden URL lesen und verstehen.
Advertencia Antes de utilizar este producto, debe leer y comprender la información de seguridad de la Guía del usuario en la siguiente URL.	Предупреждение Преди да използвате този продукт, трябва да прочетете и разберете информацията за безопасност в ръководството за потребителя на URL адреса по-долу.
Upozorenje Prije upotrebe ovog proizvoda morate pročitati i razumjeti sigurnosne informacije iz Korisničkog vodiča na donjem URL-u.	Varoványi Před použitím tohoto výrobku si musíte na níže uvedené adrese URL přečíst v návodu k použití bezpečnostní informace a porozumět jim.
Προειδοποίηση Πριν από τη χρήση αυτού του προϊόντος, πρέπει να διαβάσετε και να κατανοήσετε τις πληροφορίες ασφαλείας που περιλαμβάνει ο Οδηγός χρήστη στην παρακάτω διεύθυνση.	Aviso Antes de utilizar este produto, deve ler e compreender as informações de segurança contidas no guia do utilizador que pode encontrar no URL abaixo.
Advarsel Før du tager dette produkt i brug, skal du have læst og forstået sikkerhedsoplysningerne i brugervejledningen på webadressen nedenfor.	Figyelem A termék használatá elött el kell olvasnia és meg kell értenie a Felhasználói útmutatóban található biztonsági információkat az alábbi URL-címen.
Avvertizare Înainte de a utiliza acest produs, trebuie să citiți și să înțelegeți informațiile referitoare la siguranță din Ghidul de utilizare de la adresa URL de mai jos.	Waarschuwing Vóór gebruik van dit product moet u de veiligheidsinformatie in de Handleiding op de URL hieronder lezen en begrijpen..
Upozornenie Pred použitím tohto produktu si musíte prečítať a porozumieť všetkým bezpečnostným pokynom uvedeným v Používateľskej príručke, ktorú nájdete na nasledujúcej adrese URL.	Hoiatus Enne selle toote kasutamise alustamist peate lugema ja mõistma alltoodud URL-aadressil asuvas kasutusjuhendis toodud ohutusalast teavet.
Břídinājums Pirms šā produkta lietošanas ir jāizlasa un jāizprot informācija par drošību, kas iekļauta lietošanas pamācībā tālāk norādītajā URL.	Opozorilo Pred uporabo tega izdelka morate prebrati in razumeti varnostne informacije v navodilih za uporabo na spodnjem spletnem naslovu.



Varoitus Ennen kuin käytät tätä tuotetta, sinun on luettava ja ymmärrettävä turvallisuusohjeet, jotka sisältyvät alla mainitussa verkko-osoitteessa olevaan käyttöoppaaseen.	Ispėjimas Prieš pradėdami naudoti šį gaminį perskaitykite ir įsitikinkite, kad supratote saugos informaciją, pateiktą naudotojo vadove, esančiame toliau nurodytu universaliu adresu.
Twissija Qabel ma tuża dan il-prodott inti għandek taqra u tifhem l-istruzzjonijiet ta' sikurezza fi hdan il-Gwida għall-Utent fil-URL t'isfel.	Varning Innan du använder denna produkt måste du läsa och förstå säkerhetsinformationen i användarhandboken på nedanstående URL-adress.
Ostrzeżenie Przed przystąpieniem do użytkowania produktu należy przeczytać ze zrozumieniem informacje dotyczące bezpieczeństwa przedstawione w Podręczniku użytkownika dostępnym pod następującym adresem.	



Connect with us



www.controltechniques.com

www.kbelectronics.com

©2024 Nidec Control Techniques Limited. The information contained in this brochure is for guidance only and does not form part of any contract. The accuracy cannot be guaranteed as Nidec Control Techniques Ltd have an ongoing process of development and reserve the right to change the specification of their products without notice.

Nidec Control Techniques Limited. Registered Office: The Gro, Newtown, Powys SY16 3BE.

Registered in England and Wales. Company Reg. No. 01236886.



0478-0644-09

