

CONTROL 
TECHNIQUES



UNIMOTOR HD

HIGH DYNAMIC AC BRUSHLESS SERVO MOTOR

DRIVE OBSESSED

SERVO SOLUTIONS SERIES

UNIMOTOR HD

Unimotor hd is a high dynamic brushless AC servo motor range designed for use in pulse duty applications where rapid acceleration and deceleration are required. The motors are available in frame sizes from 060 to 190.

Reliability and innovation

Unimotor hd is designed using a proven development process that prioritises innovation and reliability. This process has resulted in a market leading reputation for both performance and quality.

Matched motor and drive combinations

Drives and motors from Control Techniques are designed to function as an optimized system. Unimotor hd is the perfect partner for Digitax and Unidrive..

Accuracy and resolution to suit your application requirements

Choosing the right feedback device for your application is critical in getting optimum performance. Unimotor hd has a range of feedback options that offer different levels of accuracy and resolution to suit most applications:

- Resolver: robust for extreme applications and conditions (low accuracy, medium resolution)
- Incremental encoder: for cost-sensitive applications (low accuracy, medium resolution)
- Inductive, SinCos/Absolute: medium accuracy, high resolution
- Optical/SinCos/Absolute: high accuracy, high resolution
- EnDat protocol supported
- Safety encoder option to meet SIL 3 safety category

The ultimate motor and drive combination

Control Techniques offer drive and motor combinations that provide an optimised system in terms of ratings, performance, cost and ease of use. Unimotor hd motors fitted with high resolution EnDat encoders are pre-loaded with the motor “electronic nameplate” data during the manufacturing process. This data can be read by any of our servo drives and used to automatically optimise the drive settings. This feature simplifies commissioning and maintenance, ensures consistent performance and saves time.

Features

Unimotor hd is suitable for a wide range of industrial applications, due to its extensive range of features:

- Torque range: from 0.64 Nm to 85 Nm
- High torque to inertia ration for high dynamic performance
- Compact but powerful
- High energy dissipation parking brakes
- IP65 conformance; sealed against water spray and dust when mounted and connected
- Segmented stator design
- World class performance
- Supported by rigorous testing for performance and reliability
- Winding voltage for inverter supply of 400 V and 220 V
- Rated speeds from 1,000 to 6,000 rpm
- Larger shafts to increase torsional rigidity
- Thermal protection by PTC thermistor/ optional KTY84.130 sensor

DRIVE AND MOTOR COMBINATIONS





Conformance and standards



RoHS
Compliant



Quick reference table						
Frame size	PCD (mm)	Stall (Nm)		Inertia (kg.cm ²) Standard		Inertia (kg.cm ²) High*
060	070	0.64	1.92	0.18	0.48	N/A
067	075	1.44	4.72	0.3	0.94	1.15 1.96
089	100	3.2	10.3	0.87	3.2	3.2 6.25
115	130	5.8	18.8	2.4	8.38	7.8 16.6
142	165	10.1	38.0	5.6	27.2	23.4 56.8
190	215	51.0	85.0	22.0	103.5	89.6 227.9

High inertia motor version available with -SHJ option code refer to pages 34 - 41

ORDERING INFORMATION

Use the information below in the illustration to create an order code for a Unimotor hd.

060	UD	B	60	0	T
Frame size	Motor voltage	Stator length	Rated speed*	Brake	Connection type**
	060 - 190 frame	060 frame	060 frame	060 - 190 frame	060 frame
060	ED = 220V	A to C	60 = 6000 rpm	0 = Not fitted (Std)	S = Single cable, power & signal combined
067	UD = 400V	067 - 115 frame	067 frame	060 frame	T = YTEC type connector (std)
089		A to D	30 = 3000 rpm	5 = Parking brake	Size 1
115		142 frame	60 = 6000 rpm	067 - 142B frame	B = Power and signal 90° rotatable
142		A to E	089 frame	6 = Parking brake	D = Single cable, power & signal combined, 90° rotatable
190		190 frame	30 = 3000 rpm	142C - 190 frame	R = Power 8-way, Signal 90° rotatable
		A to F	40 = 4000 rpm	5 = Parking brake	Size 1.5
			60 = 6000 rpm	-	J = Power and signal 90° rotatable
			115 - 142 frame		E = Single cable, power & signal combined, 90° rotatable
			20 = 2000 rpm		Z = Power 8-way, Signal 90° rotatable
			30 = 3000 rpm		
			40 = 4000 rpm		
			60 = 6000 rpm		
			190 frame		
			10 = 1000 rpm		
			15 = 1500 rpm		
			20 = 2000 rpm		
			30 = 3000 rpm		

Additional options are available upon request but may require a longer lead time to complete, please check with the Drive Centre.

* Not all speeds are available on all motors. Please refer to performance pages 12-23.

** Single cable option must be fitted with KTY thermistor

For recommended connector sizes please refer to performance pages 12-23.

A	CT	A
Output shaft	Feedback device	Thermistor
060 frame	060 Frame	060 – 190 frame
A = Key	AR = Resolver	No
F = Key and half key supplied seperately	CT = Incremental Encoder	No
067 – 190 frame	EG = Inductive EnDat Multi-turn <small>(functional safety option available upon request, contact drive center for more information)</small>	Yes
B = Plain Shaft	FG = Inductive EnDat Single-turn <small>(functional safety option available upon request, contact drive center for more information)</small>	Yes
A = Key	067 frame	
F = Key and half key supplied seperately	AR = Resolver	No
	CR = Incremental Encoder	No
	CT = Incremental Encoder	No
	EM = Inductive EnDat SinCos Multi-turn	No
	FM = Inductive EnDat SinCos Single-turn	No
	EG = Inductive EnDat Multi-turn <small>(functional safety option available upon request, contact drive center for more information)</small>	Yes
	FG = Inductive EnDat Single-turn <small>(functional safety option available upon request, contact drive center for more information)</small>	Yes
	089 – 190 frame	
	AE = Resolver	No
	CA = Incremental Encoder	No
	CT = Incremental Encoder	No
	EC = Inductive EnDat SinCos Multi-turn	No
	FC = Inductive EnDat SinCos Single-turn	No
	EF = Inductive EnDat Multi-turn <small>(functional safety option available upon request, contact drive center for more information)</small>	Yes
	FF = Inductive EnDat Single-turn <small>(functional safety option available upon request, contact drive center for more information)</small>	Yes
	GB = ROHS EnDat Multi-turn Size 58	Yes
	HB = ROHS EnDat Single-turn Size 58	Yes

UNIMOTOR HD RANGE OVERVIEW

3 Phase VPWM drives 200 - 240Vrms

$\Delta t = 100^{\circ}\text{C}$ winding 40°C maximum ambient.
All data subject to +/-10% tolerance

Motor Frame Size (mm)	060ED			067ED				089ED				115ED			
Frame length	A	B	C	A	B	C	D	A	B	C	D	A	B	C	D
Continuous stall torque (Nm)	0.64	1.28	1.92	1.44	2.55	3.70	4.72	3.20	5.50	8.00	10.30	5.80	10.20	14.60	18.80
Peak torque (Nm)	2.24	4.48	6.72	4.35	7.65	11.10	14.60	9.60	16.50	24.00	31.50	17.40	30.60	43.80	56.40
Standard inertia	0.18	0.33	0.48	0.30	0.53	0.75	0.94	0.87	1.61	2.34	3.20	2.40	4.41	6.39	8.38
Standard motor weight (kg)	1.6	2.0	2.2	1.96	2.56	3.16	3.80	3.18	4.28	5.38	6.48	5.20	6.95	8.72	10.49
High inertia (kg cm ²)	-	-	-	1.15	1.42	1.69	1.96	3.23	4.24	5.24	6.25	7.84	10.78	13.70	16.63
High inertia motor weight (kg)	-	-	-	2.29	2.89	3.49	4.13	3.73	4.83	5.93	7.03	6.04	7.79	9.56	11.33
Number of poles	10	10	10	10	10	10	10	10	10	10	10	10	10	10	10
Speed 2000 (rpm)								Kt(Nm/A) = 1.4 Ke(V/Krpm) = 85.5							
Rated torque (Nm)	-	-	-	-	-	-	-	-	-	-	-	-	-	11.9	15.6
Stall current (A)	-	-	-	-	-	-	-	-	-	-	-	-	-	10.53	13.56
Rated power (kW)	-	-	-	-	-	-	-	-	-	-	-	-	-	2.49	3.27
Recommended power conn' size	-	-	-	-	-	-	-	-	-	-	-	-	-	1	1
Speed 3000 (rpm)								Kt(Nm/A) = 0.93 Ke(V/Krpm) = 57							
Rated Torque (Nm)	-	-	-	1.40	2.45	3.50	4.60	3.00	4.85	6.90	8.50	4.80	7.70	10.50	-
Stall Current (A)	-	-	-	1.56	2.76	4.00	5.11	3.46	5.95	8.66	11.15	6.28	11.04	15.80	-
Rated Power (kW)	-	-	-	0.44	0.77	1.10	2.50	0.94	1.52	2.17	2.67	1.51	2.42	3.30	-
Recommended power conn' size	-	-	-	1	1	1	1	1	1	1	1	1	1	1	-
Speed 4000 (rpm)								Kt(Nm/A) = 0.7 Ke(V/Krpm) = 42.75							
Rated Torque (Nm)	-	-	-	-	-	-	-	-	4.55	6.35	-	-	-	8.70	-
Stall Current (A)	-	-	-	-	-	-	-	-	7.94	11.54	-	-	-	21.07	-
Rated Power (kW)	-	-	-	-	-	-	-	-	1.91	2.66	-	-	-	3.64	-
Recommended power conn' size	-	-	-	-	-	-	-	-	1	1	-	-	-	1	-
Speed 6000 (rpm)								Kt(Nm/A) = 0.47 Ke(V/Krpm) = 28.5							
Rated Torque (Nm)	-	-	-	1.3	2.2	3.1	4.0	2.65	3.80	5.00	-	3.60	4.80	-	-
Stall Current (A)	-	-	-	3.12	5.52	8.01	10.22	6.93	11.90	17.32	-	12.55	22.08	-	-
Rated Power (kW)	-	-	-	0.82	1.38	1.95	2.66	1.67	2.39	3.14	-	2.27	3.02	-	-
Recommended power conn' size	-	-	-	1	1	1	1	1	1	1	-	1	1	-	-

Stall torque, rated torque and power relate to maximum continuous operation tested in a 20°C ambient at 12kHz drive switching frequency

All other figures relate to a 20°C motor temperature.
Maximum intermittent winding temperature is 140°C

142ED					190ED						Motor Frame Size (mm)
A	B	C	D	E	A	B	C	D	E	F	Frame length
10.10	17.40	25.00	31.50	38.00	18.50	32.70	52.00	62.00	73.50	85.00	Continuous stall torque (Nm)
30.30	55.30	74.90	94.50	114.00	51.00	95.00	156.00	186.00	221.00	255.00	Peak torque (Nm)
5.60	11.00	17.00	22.10	27.20	22.00	38.30	54.60	70.90	87.20	103.50	Standard inertia
7.40	10.10	12.74	15.39	18.04	14.60	21.20	27.74	34.30	40.90	47.42	Standard motor weight (kg)
23.40	31.75	40.11	48.46	56.80	89.63	117.28	144.93	172.58	200.23	227.88	High inertia (kg cm ²)
8.92	11.62	14.26	16.91	19.56	17.27	23.87	30.41	36.97	43.57	50.09	High inertia motor weight (kg)
10	10	10	10	10	10	10	10	10	10	10	Number of poles
Kt(Nm/A) = 1.4 Ke(V/Krpm) = 85.5					Kt(Nm/A) = 2.8 Ke(V/Krpm) = 171						190 frame Speed 1000 (rpm)
8.6	15.3	21.4	-	-	17.6	-	49.0	56.5	-	77.5	Rated torque (Nm)
7.29	12.55	18.04	-	-	6.67	-	17.32	22.37	-	30.66	Stall current (A)
1.80	3.20	4.48	-	-	1.83	-	5.13	5.92	-	8.12	Rated power (kW)
1	1	1.5	-	-	1.5	-	1.5	1.5	-	1.5	Recommended power conn' size
Kt(Nm/A) = 0.93 Ke(V/Krpm) = 57					Kt(Nm/A) = 1.86 Ke(V/Krpm) = 114						190 frame Speed 1500 (rpm)
8.20	14.00	18.40	20.90	-	-	-	46.20	-	-	-	Rated Torque (Nm)
10.93	18.83	27.06	34.09	-	-	-	25.97	-	-	-	Stall Current (A)
2.58	4.40	5.78	6.57	-	-	-	7.26	-	-	-	Rated Power (kW)
1	1.5	1.5	1.5	-	-	-	1.5	-	-	-	Recommended power conn' size
Kt(Nm/A) = 0.7 Ke(V/Krpm) = 42.75					Kt(Nm/A) = 1.4 Ke(V/Krpm) = 85.5						190 frame Speed 2000 (rpm)
-	11.70	-	-	-	-	-	42.50	-	-	-	Rated Torque (Nm)
-	25.11	-	-	-	-	-	34.63	-	-	-	Stall Current (A)
-	4.89	-	-	-	-	-	8.90	-	-	-	Rated Power (kW)
-	1.5	-	-	-	-	-	1.5	-	-	-	Recommended power conn' size
Kt(Nm/A) = 0.47 Ke(V/Krpm) = 28.5					Kt(Nm/A) = 0.93 Ke(V/Krpm) = 57						190 frame Speed 3000 (rpm)
-	-	-	-	-	15.50	25.00	32.80	-	-	-	Rated Torque (Nm)
-	-	-	-	-	20.02	35.39	51.95	-	-	-	Stall Current (A)
-	-	-	-	-	4.87	7.85	10.30	-	-	-	Rated Power (kW)
-	-	-	-	-	1.5	1.5	1.5	-	-	-	Recommended power conn' size

- Not available

UNIMOTOR HD RANGE OVERVIEW

3 Phase VPWM drives 380 - 480Vrms

$\Delta t = 100^{\circ}\text{C}$ winding 40°C maximum ambient.
All data subject to +/-10% tolerance

Motor Frame Size (mm)	060UD			067UD				089UD				115UD				
Frame length	A	B	C	A	B	C	D	A	B	C	D	A	B	C	D	
Continuous stall torque (Nm)	0.64	1.28	1.92	1.44	2.55	3.70	4.72	3.20	5.50	8.00	10.30	5.80	10.20	14.60	18.80	
Peak torque (Nm)	2.24	4.48	6.72	4.35	7.65	11.10	14.60	9.60	16.50	24.00	31.50	17.40	30.60	43.80	56.40	
Standard inertia	0.18	0.33	0.48	0.30	0.53	0.75	0.94	0.87	1.61	2.34	3.20	2.40	4.41	6.39	8.38	
Standard motor weight (kg)	1.6	2.0	2.2	1.96	2.56	3.16	3.80	3.18	4.28	5.38	6.48	5.20	6.95	8.72	10.49	
High inertia (kg cm ²)	-	-	-	1.15	1.42	1.69	1.96	3.23	4.24	5.24	6.25	7.84	10.78	13.70	16.63	
High inertia motor weight (kg)	-	-	-	2.29	2.89	3.49	4.13	3.73	4.83	5.93	7.03	6.04	7.79	9.56	11.33	
Number of poles	10	10	10	10	10	10	10	10	10	10	10	10	10	10	10	
Speed 2000 (rpm)				$K_t(\text{Nm/A}) = 2.4$ $K_e(\text{V/Krpm}) = 147$												
Rated torque (Nm)	-	-	-	-	-	-	-	-	-	-	-	-	-	-	11.9	15.6
Stall current (A)	-	-	-	-	-	-	-	-	-	-	-	-	-	-	6.05	7.79
Rated power (kW)	-	-	-	-	-	-	-	-	-	-	-	-	-	-	2.49	3.27
Recommended power conn' size	-	-	-	-	-	-	-	-	-	-	-	-	-	-	1	1
Speed 3000 (rpm)				$K_t(\text{Nm/A}) = 1.6$ $K_e(\text{V/Krpm}) = 98$												
Rated Torque (Nm)	-	-	-	1.40	2.45	3.50	4.60	3.00	4.85	6.90	8.50	4.80	7.70	10.50	13.60	
Stall Current (A)	-	-	-	1.81	1.59	2.30	2.93	1.99	3.42	4.97	6.40	3.61	6.34	9.08	11.69	
Rated Power (kW)	-	-	-	0.44	0.77	1.10	2.50	0.94	1.52	2.17	2.67	1.51	2.42	3.30	4.27	
Recommended power conn' size	-	-	-	1	1	1	1	1	1	1	1	1	1	1	1	
Speed 4000 (rpm)				$K_t(\text{Nm/A}) = 1.2$ $K_e(\text{V/Krpm}) = 74$												
Rated Torque (Nm)	-	-	-	-	-	-	-	-	4.55	6.35	-	-	-	8.70	-	
Stall Current (A)	-	-	-	-	-	-	-	-	4.56	6.63	-	-	-	12.10	-	
Rated Power (kW)	-	-	-	-	-	-	-	-	1.91	2.66	-	-	-	3.64	-	
Recommended power conn' size	-	-	-	-	-	-	-	-	1	1	-	-	-	1	-	
Speed 6000 (rpm)				$K_t(\text{Nm/A}) = 0.8$ $K_e(\text{V/Krpm}) = 49$												
Rated Torque (Nm)	-	-	-	1.30	2.20	3.10	4.00	2.65	3.80	5.00	-	3.60	4.80	-	-	
Stall Current (A)	-	-	-	1.81	3.17	4.60	5.87	3.98	6.84	9.95	-	7.21	12.68	-	-	
Rated Power (kW)	-	-	-	0.82	1.38	1.95	2.66	1.67	2.39	3.14	-	2.27	3.02	-	-	
Recommended power conn' size	-	-	-	1	1	1	1	1	1	1	-	1	1	-	-	

Stall torque, rated torque and power relate to maximum continuous operation tested in a 20°C ambient at 12kHz drive switching frequency

All other figures relate to a 20°C motor temperature.
Maximum intermittent winding temperature is 140°C

142UD					190UD						Motor Frame Size (mm)
A	B	C	D	E	A	B	C	D	E	F	Frame length
10.10	17.40	25.00	31.50	38.00	18.50	32.70	32.00	62.00	73.50	85.00	Continuous stall torque (Nm)
30.30	55.30	74.90	94.50	114.00	51.00	95.00	156.00	186.00	221.00	255.00	Peak torque (Nm)
5.60	11.00	17.00	22.10	27.20	22.00	38.30	54.60	70.90	87.20	103.50	Standard inertia
7.40	10.10	12.74	15.39	18.04	14.60	21.20	27.74	34.30	40.90	47.42	Standard motor weight (kg)
23.40	31.75	40.11	48.46	56.80	89.63	117.28	144.93	172.58	200.23	227.88	High inertia (kg cm ²)
8.92	11.62	14.26	16.91	19.56	17.27	23.87	30.41	36.97	43.57	50.09	High inertia motor weight (kg)
10	10	10	10	10	10	10	10	10	10	10	Number of poles
Kt(Nm/A) = 2.4 Ke(V/Krpm) = 147					Kt(Nm/A) = 4.8 Ke(V/Krpm) = 296						190 frame Speed 1000 (rpm)
8.6	15.3	21.4	-	-	17.6	-	-	-	-	78.3	Rated torque (Nm)
4.19	7.21	10.36	-	-	3.83	-	-	-	-	17.61	Stall current (A)
1.80	3.20	4.48	-	-	1.83	-	-	-	-	8.12	Rated power (kW)
1	1	1	-	-	1.5	-	-	-	-	1.5	Recommended power conn' size
Kt(Nm/A) = 1.6 Ke(V/Krpm) = 98					Kt(Nm/A) = 3.2 Ke(V/Krpm) = 196						190 frame Speed 1500 (rpm)
8.20	14.00	18.40	20.90	23.00	-	-	46.20	-	-	68.50	Rated Torque (Nm)
6.28	10.82	15.54	19.58	23.62	-	-	14.92	-	-	26.42	Stall Current (A)
2.58	4.40	5.78	6.57	7.23	-	-	7.26	-	-	10.76	Rated Power (kW)
1	1	1	1.5	1.5	-	-	1.5	-	-	1.5	Recommended power conn' size
Kt(Nm/A) = 1.2 Ke(V/Krpm) = 74					Kt(Nm/A) = 2.4 Ke(V/Krpm) = 147						190 frame Speed 2000 (rpm)
-	11.70	-	14.90	-	-	-	42.50	45.30	52.90	56.00	Rated Torque (Nm)
-	14.42	-	26.11	-	-	-	19.89	25.69	30.46	35.22	Stall Current (A)
-	4.89	-	6.26	-	-	-	8.90	9.50	11.07	11.70	Rated Power (kW)
-	1	-	1.5	-	-	-	1.5	1.5	1.5	1.5	Recommended power conn' size
Kt(Nm/A) = 0.8 Ke(V/Krpm) = 49					Kt(Nm/A) = 1.6 Ke(V/Krpm) = 98						190 frame Speed 3000 (rpm)
-	7.00	-	-	-	15.50	25.00	32.80	39.00	-	-	Rated Torque (Nm)
-	21.63	-	-	-	11.50	20.33	29.84	38.54	-	-	Stall Current (A)
-	4.40	-	-	-	4.87	7.85	10.30	13.82	-	-	Rated Power (kW)
-	1.5	-	-	-	1.5	1.5	1.5	1.5	-	-	Recommended power conn' size

- Not available

UNIMOTOR HD

RATINGS AND DIMENSIONS

FRAME SIZE 060

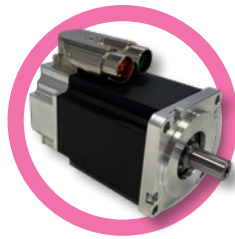

Motor frame size (mm)	060ED		
Voltage (Vrms)	200-240		
Frame length	A	B	C
Continuous stall torque (Nm)	0.64	1.28	1.92
Peak torque (Nm)	2.24	4.48	6.72
Standard inertia (kg cm ²)	0.18	0.33	0.48
Standard motor weight (kg)	1.6	2.0	2.2
Number of poles	10	10	10
Speed 6000 (rpm)	0.47 Kt (Nm/A) = Ke (V/krpm) = 28.5		
Rated torque (Nm)	0.64	1.28	1.92
Stall current (A)	1.36	2.72	4.09
Rated power (kW)	0.4	0.8	1.2
R (ph-ph) (Ohms)	5.15	1.90	1.15
L (ph-ph) (mH)	23.8	11.1	7.3
Recommended power conn' size	Y-TEC		

Motor frame size (mm)	060UD		
Voltage (Vrms)	380-480		
Frame length	A	B	C
Continuous stall torque (Nm)	0.64	1.28	1.92
Peak torque (Nm)	2.24	4.48	6.72
Standard inertia (kg cm ²)	0.18	0.33	0.48
Standard motor weight (kg)	1.6	2.0	2.2
Number of poles	10	10	10
Speed 6000 (rpm)	0.8 Kt (Nm/A) = Ke (V/krpm) = 49		
Rated torque (Nm)	0.64	1.28	1.92
Stall current (A)	0.8	1.6	2.4
Rated power (kW)	0.4	0.8	1.2
R (ph-ph) (Ohms)	24.00	10.10	5.90
L (ph-ph) (mH)	91.5	46.8	32.6
Recommended power conn' size	Y-TEC		

All data subject to +/-10% tolerance
 Stall torque, rated torque and power relate to maximum continuous operation tested in a 20°C ambient at 12 kHz drive switching frequency
 All other figures relate to a 20°C motor temperature.
 Maximum intermittent winding temperature is 140°C

	Motor Dimension														
	Feedback CT				Flange thickness	Register length	Register diameter	Overall height	Flange square	Fixing hole diameter	Fixing hole PCD	Motor housing	Mounting bolts		
	Unbraked length		Braked length											LA (±0.5)	T (±0.1)
	LB (±0.9)	LC (±1.0)	LC (±1.0)	LC (±1.0)											
060A	82.5	66.5	119.5	103.5											
060B	102.5	86.5	139.5	123.5	7.5	3	50	80	60	5.5	70	60	M5	mm	
060C	122.5	106.5	159.5	143.5											



	Shaft Dimension								Tapped hole depth
	Shaft diameter	Shaft length	Key height	Key length	Key to shaft end	Key width	Tapped hole thread size	Tapped hole depth	
	D(j6)	E	GA	GF	G	F(h9)	I	J(±1)	
14.0 Std	14	30	16	22	1.5	5	M5 x 0.8	10	mm

	Feedback EG, FG	
	Unbraked length	Braked length
	LB (± 0.9)	LB (± 0.9)
060A	100	137
060B	120	157
060C	140	177

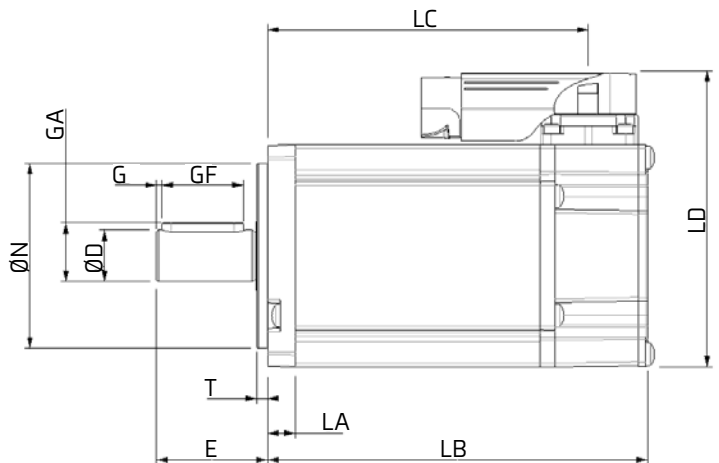
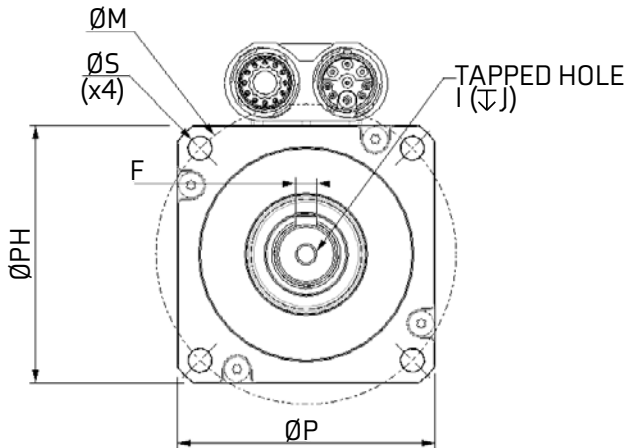

FRAME SIZE 067

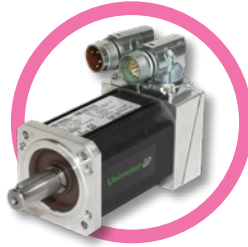

Motor frame size (mm)		067ED			
Voltage (Vrms)		200-240			
Frame length		A	B	C	D
Continuous stall torque (Nm)		1.44	2.55	3.70	4.72
Peak torque (Nm)		4.35	7.65	11.10	14.60
Standard inertia (kg cm ²)		0.30	0.53	0.75	0.94
Winding thermal time constant (sec)		54	61	65	68
Standard motor weight (kg)		1.96	2.56	3.16	3.80
Number of poles		10	10	10	10
Speed 3000 (rpm)	K_t (Nm/A) = K_e (V/krpm) =	0.93 57			
Rated torque (Nm)		1.40	2.45	3.50	4.60
Stall current (A)		1.55	2.74	3.98	5.08
Rated power (kW)		0.44	0.77	1.10	1.45
R (ph-ph) (Ohms)		15.16	5.85	3.33	2.32
L (ph-ph) (mH)		46.7	20.6	12.7	10.6
Recommended power conn' size		1	1	1	1
Speed 6000 (rpm)	K_t (Nm/A) = K_e (V/krpm) =	0.47 28.5			
Rated torque (Nm)		1.3	2.2	3.1	4.0
Stall current (A)		3.06	5.43	7.87	10.04
Rated power (kW)		0.82	1.38	1.95	2.51
R (ph-ph) (Ohms)		3.79	1.46	0.76	0.54
L (ph-ph) (mH)		11.7	5.2	3.6	2.03
Recommended power conn' size		1	1	1	1

Motor frame size (mm)		067UD			
Voltage (Vrms)		380-480			
Frame length		A	B	C	D
Continuous stall torque (Nm)		1.44	2.55	3.70	4.72
Peak torque (Nm)		4.35	7.65	11.10	14.60
Standard inertia (kg cm ²)		0.30	0.53	0.75	0.94
Winding thermal time constant (sec)		54	61	65	68
Standard motor weight (kg)		1.96	2.56	3.16	3.80
Number of poles		10	10	10	10
Speed 3000 (rpm)	K_t (Nm/A) = K_e (V/krpm) =	0.8 49		1.5 98	
Rated torque (Nm)		1.40	2.45	3.50	4.60
Stall current (A)		1.80	1.59	2.31	2.95
Rated power (kW)		0.44	0.77	1.10	1.45
R (ph-ph) (Ohms)		11.69	18.55	10.70	6.42
L (ph-ph) (mH)		35.2	65.6	40.8	31.2
Recommended power conn' size		1	1	1	1
Speed 6000 (rpm)	K_t (Nm/A) = K_e (V/krpm) =	0.8 49			
Rated torque (Nm)		1.3	2.2	3.1	4.0
Stall current (A)		1.80	3.19	4.63	5.90
Rated power (kW)		0.82	1.38	1.95	2.51
R (ph-ph) (Ohms)		11.69	4.64	2.73	1.60
L (ph-ph) (mH)		35.2	16.4	10.2	7.8
Recommended power conn' size		1	1	1	1

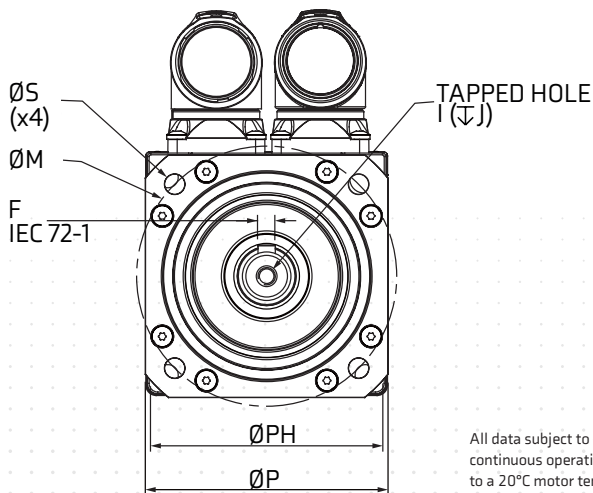

All data subject to +/- 10% tolerance. Stall torque, rated torque and power relate to maximum continuous operation tested in a 20°C ambient at 1kHz drive switching frequency. All other figures relate to a 20°C motor temperature. Maximum intermittent winding temperature is 140°C

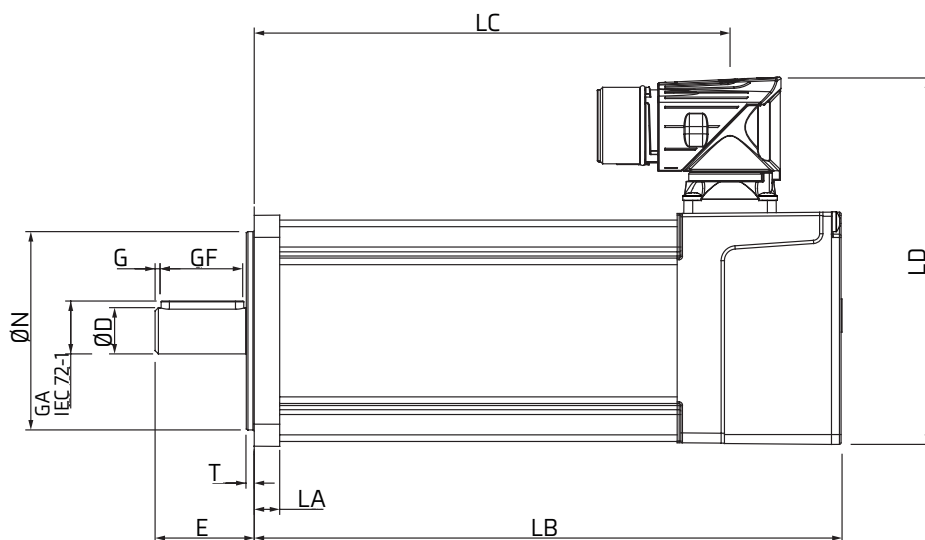

Motor Dimension															
	Feedback AR, CR, EM, FM, EG, FG				Flange thickness	Register length	Register diameter	Overall height	Flange square	Fixing hole diameter	Fixing hole PCD	Motor housing	Mounting bolts		
	Unbraked length	Braked length												LD (±0.3)	P (±0.3)
	LB (±0.9)	LC (±1.0)	LC (±1.0)	LC (±1.0)	LA (±0.5)	T (±0.1)	N (j6)	LD (±0.3)	P (±0.3)	S (H14)	M (±0.5)	PH (±0.5)			
067A	142.9	109	177.9	144	7.7	2.5	60	111.5	70	5.8	75	67	M5	mm	
067B	172.9	139	207.9	174											
067C	202.9	169	237.9	204											
067D	232.9	199	267.9	234											

Shaft Dimension								
	Shaft diameter	Shaft length	Key height	Key length	Key to shaft end	Key width	Tapped hole thread size	Tapped hole depth
	D(j6)	E	GA	GF	G	F(h9)	I	J(±1)
14.0 Std	14	30	16	25	1.5	5	M5 x 0.8	13.5 mm

19mm shaft and 90mm flange options are available. Refer to factory for more information.

FRAME SIZE 089



Motor frame size (mm)		089ED			
Voltage (Vrms)		200-240			
Frame length		A	B	C	D
Continuous stall torque (Nm)		3.2	5.5	8.0	10.3
Peak torque (Nm)		9.6	16.5	24.0	30.9
Standard inertia (kg cm ²)		0.87	1.61	2.34	3.20
Winding thermal time constant (sec)		85	93	98	103
Standard motor weight (kg)		3.18	4.28	5.38	6.48
Number of poles		10	10	10	10
Speed 3000 (rpm)	Kt (Nm/A) = Ke (V/krpm) =	0.93 57			
Rated torque (Nm)		3.00	4.85	6.90	8.50
Stall current (A)		3.44	5.91	8.60	11.08
Rated power (kW)		0.94	1.52	2.17	2.67
R (ph-ph) (Ohms)		4.1	1.64	0.93	0.45
L (ph-ph) (mH)		25.0	11.8	7.1	13.7
Recommended power conn' size		1	1	1	1
Speed 4000 (rpm)	Kt (Nm/A) = Ke (V/krpm) =	0.47 42.75			
Rated torque (Nm)		◆	4.55	6.35	◆
Stall current (A)		◆	7.86	11.43	◆
Rated power (kW)		◆	1.91	2.66	◆
R (ph-ph) (Ohms)		◆	0.82	0.56	◆
L (ph-ph) (mH)		◆	6	4.3	◆
Recommended power conn' size		◆	1	1	◆
Speed 6000 (rpm)	Kt (Nm/A) = Ke (V/krpm) =	0.47 28.5			
Rated torque (Nm)		2.65	3.80	5.00	◆
Stall current (A)		6.93	11.70	17.02	◆
Rated power (kW)		1.67	2.39	3.14	◆
R (ph-ph) (Ohms)		1.03	0.41	0.24	◆
L (ph-ph) (mH)		6.2	2.96	1.77	◆
Recommended power conn' size		1	1	1	◆

Motor frame size (mm)		089UD			
Voltage (Vrms)		380-480			
Frame length		A	B	C	D
Continuous stall torque (Nm)		3.2	5.5	8.0	10.3
Peak torque (Nm)		9.6	16.5	24.0	31.5
Standard inertia (kg cm ²)		0.87	1.61	2.34	3.20
Winding thermal time constant (sec)		85	93	98	103
Standard motor weight (kg)		3.18	4.28	5.38	6.48
Number of poles		10	10	10	10
Speed 3000 (rpm)	Kt (Nm/A) = Ke (V/krpm) =	1.6 98			
Rated torque (Nm)		3.00	4.85	6.90	8.50
Stall current (A)		2.00	3.44	5.00	6.44
Rated power (kW)		0.94	1.52	2.17	2.67
R (ph-ph) (Ohms)		10.80	5.18	2.79	1.89
L (ph-ph) (mH)		66.8	36.7	21.7	17.5
Recommended power conn' size		1	1	1	1
Speed 4000 (rpm)	Kt (Nm/A) = Ke (V/krpm) =	1.2 73.5			
Rated torque (Nm)		◆	4.55	6.35	◆
Stall current (A)		◆	4.58	6.67	◆
Rated power (kW)		◆	1.91	2.66	◆
R (ph-ph) (Ohms)		◆	2.60	1.80	◆
L (ph-ph) (mH)		◆	18.8	13.4	◆
Recommended power conn' size		◆	1	1	◆
Speed 6000 (rpm)	Kt (Nm/A) = Ke (V/krpm) =	0.8 49			
Rated torque (Nm)		2.65	3.80	5.00	◆
Stall current (A)		4.00	6.88	10.00	◆
Rated power (kW)		1.67	2.39	3.14	◆
R (ph-ph) (Ohms)		2.70	1.30	0.67	◆
L (ph-ph) (mH)		16.7	9.2	5.4	◆
Recommended power conn' size		1	1	1	◆

◆ Not available

All data subject to +/-10% tolerance. Stall torque, rated torque and power relate to maximum continuous operation tested in a 20°C ambient at 12kHz drive switching frequency. All other figures relate to a 20°C motor temperature. Maximum intermittent winding temperature is 140°C

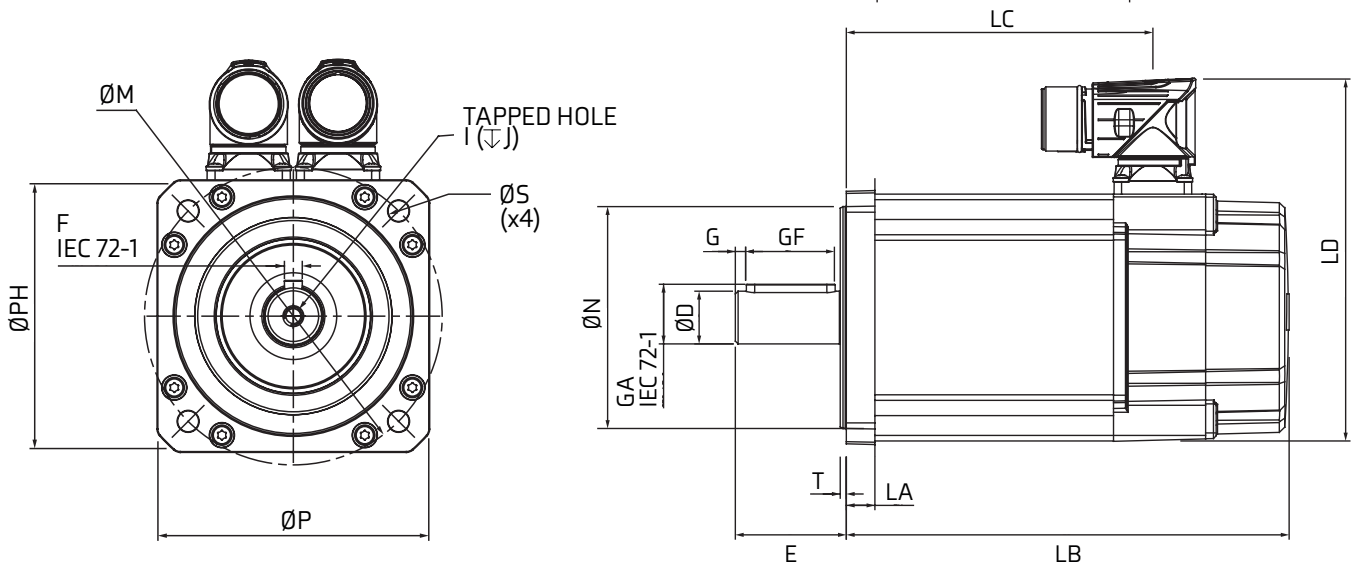

Motor Dimension															
	Feedback EC, FC, EF, FF				Flange thickness	Register length	Register diameter	Overall height	Flange square	Fixing hole diameter	Fixing hole PCD	Motor housing	Mounting bolts		
	Unbraked length		Braked length											LA (± 0.5)	T (± 0.1)
	LB (± 0.9)	LC (± 1.0)	LC (± 1.0)	LC (± 1.0)											mm
089A	147.8	110.5	187.9	150.6	10.3	2.2	80	130.5	91	7	100	89	M6		
089B	177.8	140.5	217.9	180.6											
089C	207.8	170.5	247.9	210.6											
089D	237.8	200.5	277.9	240.6											

Shaft Dimension									
	Shaft diameter	Shaft length	Key height	Key length	Key to shaft end	Key width	Tapped hole thread size	Tapped hole depth	
	D (j6)	E	GA	GF	G	F (h9)	I	J (± 1)	mm
19.0 Std	19	40	21.5	32	3.7	6	M6 x 1	17	mm

24mm shaft and 115mm flange options are available. Refer to factory for more information.

	Feedback CA, GB, HB		Feedback AE		
	Unbraked length	Braked length	Unbraked length	Braked length	
	LB (± 0.9)	LB (± 0.9)	LB (± 0.9)	LB (± 0.9)	
089A	160.8	200.9	137.8	177.9	mm
089B	190.8	230.9	167.8	207.9	
089C	220.8	260.9	197.8	237.9	
089D	250.8	290.9	227.8	267.9	

FRAME SIZE 115

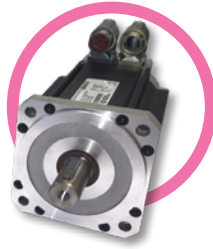

Motor frame size (mm)		115ED			
Voltage (Vrms)		200-240			
Frame length		A	B	C	D
Continuous stall torque (Nm)		5.8	10.2	14.6	18.8
Peak torque (Nm)		17.4	30.6	43.8	56.4
Standard inertia (kg cm ²)		2.40	4.41	6.39	8.38
Winding thermal time constant (sec)		161	164	168	175
Standard motor weight (kg)		5.20	6.95	8.72	10.49
Number of poles		10	10	10	10
Speed 2000 (rpm)	Kt (Nm/A) = Ke (V/krpm) =			1.4 85.5	
Rated torque (Nm)		◆	◆	11.9	15.6
Stall current (A)		◆	◆	10.43	13.43
Rated power (kW)		◆	◆	2.49	3.27
R (ph-ph) (Ohms)		◆	◆	0.77	0.61
L (ph-ph) (mH)		◆	◆	7.9	6.6
Recommended power conn' size		◆	◆	1	1
Speed 3000 (rpm)	Kt (Nm/A) = Ke (V/krpm) =			0.93 57	
Rated torque (Nm)		4.8	7.7	10.5	◆
Stall current (A)		6.24	10.97	15.70	◆
Rated power (kW)		1.51	2.42	3.30	◆
R (ph-ph) (Ohms)		1.59	0.58	0.39	◆
L (ph-ph) (mH)		12.8	5.4	4.0	◆
Recommended power conn' size		1	1	1	◆
Speed 4000 (rpm)	Kt (Nm/A) = Ke (V/krpm) =			0.7 42.75	
Rated torque (Nm)		◆	◆	8.7	◆
Stall current (A)		◆	◆	20.86	◆
Rated power (kW)		◆	◆	3.64	◆
R (ph-ph) (Ohms)		◆	◆	0.12	◆
L (ph-ph) (mH)		◆	◆	4	◆
Recommended power conn' size		◆	◆	1	◆
Speed 6000 (rpm)	Kt (Nm/A) = Ke (V/krpm) =			0.47 28.5	
Rated torque (Nm)		3.6	4.8	◆	◆
Stall current (A)		12.34	21.70	◆	◆
Rated power (kW)		2.26	3.02	◆	◆
R (ph-ph) (Ohms)		0.40	0.09	◆	◆
L (ph-ph) (mH)		3.2	2.8	◆	◆
Recommended power conn' size		1	1	◆	◆

◆ Not available

Motor frame size (mm)		115UD			
Voltage (Vrms)		380-480			
Frame length		A	B	C	D
Continuous stall torque (Nm)		5.8	10.2	14.6	18.8
Peak torque (Nm)		17.4	30.6	43.8	56.4
Standard inertia (kg cm ²)		2.40	4.41	6.39	8.38
Winding thermal time constant (sec)		161	164	168	175
Standard motor weight (kg)		5.20	6.95	8.72	10.49
Number of poles		10	10	10	10
Speed 2000 (rpm)	Kt (Nm/A) = Ke (V/krpm) =			2.4 147	
Rated torque (Nm)		◆	◆	11.9	15.6
Stall current (A)		◆	◆	6.08	7.83
Rated power (kW)		◆	◆	2.49	3.27
R (ph-ph) (Ohms)		◆	◆	2.41	1.80
L (ph-ph) (mH)		◆	◆	24.7	19.5
Recommended power conn' size		◆	◆	1	1
Speed 3000 (rpm)	Kt (Nm/A) = Ke (V/krpm) =			1.6 98	
Rated torque (Nm)		4.8	7.7	10.5	13.6
Stall current (A)		3.03	6.38	9.13	11.75
Rated power (kW)		1.51	2.42	3.30	4.27
R (ph-ph) (Ohms)		5.00	1.90	1.21	0.78
L (ph-ph) (mH)		40.3	18.0	12.7	8.7
Recommended power conn' size		1	1	1	1
Speed 4000 (rpm)	Kt (Nm/A) = Ke (V/krpm) =			1.2 73.5	
Rated torque (Nm)		◆	◆	8.7	◆
Stall current (A)		◆	◆	12.1	◆
Rated power (kW)		◆	◆	3.64	◆
R (ph-ph) (Ohms)		◆	◆	0.6	◆
L (ph-ph) (mH)		◆	◆	6.6	◆
Recommended power conn' size		◆	◆	1	◆
Speed 6000 (rpm)	Kt (Nm/A) = Ke (V/krpm) =			0.8 49	
Rated torque (Nm)		3.6	4.8	◆	◆
Stall current (A)		7.25	12.75	◆	◆
Rated power (kW)		2.26	3.02	◆	◆
R (ph-ph) (Ohms)		1.25	0.47	◆	◆
L (ph-ph) (mH)		10.1	4.5	◆	◆
Recommended power conn' size		1	1	◆	◆

All data subject to +/-10% tolerance. Stall torque, rated torque and power relate to maximum continuous operation tested in a 20°C ambient at 12kHz drive switching frequency. All other figures relate to a 20°C motor temperature. Maximum intermittent winding temperature is 140°C

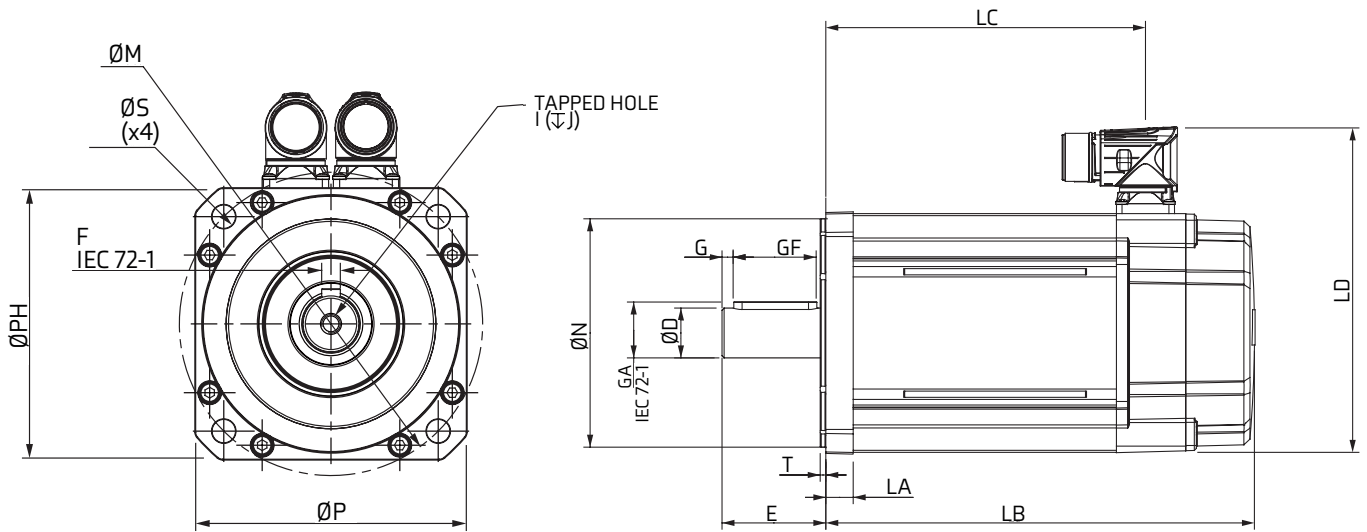

Motor Dimension															
Feedback EC, FC, EF, FF					Flange thickness	Register length	Register diameter	Overall height	Flange square	Fixing hole diameter	Fixing hole PCD	Motor housing	Mounting bolts		
Unbraked length		Braked length													
	LB (± 0.9)	LC (± 1.0)	LC (± 1.0)	LC (± 1.0)	LA (± 0.5)	T (± 0.1)	N (j6)	LD (± 0.3)	P (± 0.3)	S (H14)	M (± 0.5)	PH (± 0.5)			
115A	163.8	124	200.9	161.1	13.2	2.7	110	156.5	116	10	130	115	M8	mm	
115B	193.8	154	230.9	191.1											
115C	223.8	184	260.9	221.1											
115D	253.8	214	290.9	251.1											

Shaft Dimension									
	Shaft diameter	Shaft length	Key height	Key length	Key to shaft end	Key width	Tapped hole thread size	Tapped hole depth	
	D (j6)	E	GA	GF	G	F (h9)	I	J (± 1)	
24mm Std	24	50	27	40	5.3	8	M8 x 1.25	20	mm

28mm shaft and 145mm flange options are available. Refer to factory for more information.

	Feedback CA, GB, HB		Feedback AE		
	Unbraked length	Braked length	Unbraked length	Braked length	
	LB (± 0.9)	LB (± 0.9)	LB (± 0.9)	LB (± 0.9)	
115A	176.8	213.9	153.8	190.9	mm
115B	206.8	243.9	183.8	220.9	
115C	236.8	273.9	213.8	250.9	
115D	266.8	303.9	243.8	280.9	

FRAME SIZE 142

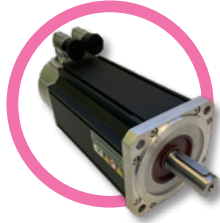

Motor frame size (mm)		142ED				
Voltage (Vrms)		200-240				
Frame length		A	B	C	D	E
Continuous stall torque (Nm)		10.1	17.4	25.0	31.5	38.0
Peak torque (Nm)		30.3	52.2	75.0	94.5	114.0
Standard inertia (kg cm ²)		5.6	11.0	17.0	22.1	27.2
Winding thermal time constant (sec)		235	240	245	251	256
Standard motor weight (kg)		7.40	10.10	12.74	15.39	18.04
Number of poles		10	10	10	10	10
Speed 2000 (rpm)	Kt (Nm/A) = Ke (V/krpm) =	1.4 85.5				
Rated torque (Nm)		8.6	15.3	21.4	◆	◆
Stall current (A)		7.21	12.43	17.86	◆	◆
Rated power (kW)		1.80	3.20	4.48	◆	◆
R (ph-ph) (Ohms)		0.85	0.34	0.24	◆	◆
L (ph-ph) (mH)		14.3	5.9	3.7	◆	◆
Recommended power conn' size		1	1	1.5	◆	◆
Speed 3000 (rpm)	Kt (Nm/A) = Ke (V/krpm) =	0.93 57				
Rated torque (Nm)		8.2	14.0	18.4	20.9	◆
Stall current (A)		10.86	18.71	26.88	33.87	◆
Rated power (kW)		2.58	4.40	5.78	6.57	◆
R (ph-ph) (Ohms)		0.38	0.22	0.12	0.09	◆
L (ph-ph) (mH)		6.3	2.8	1.9	1.6	◆
Recommended power conn' size		1	1.5	1.5	1.5	◆
Speed 4000 (rpm)	Kt (Nm/A) = Ke (V/krpm) =	0.7 42.75				
Rated torque (Nm)		◆	11.7	◆	◆	◆
Stall current (A)		◆	24.86	◆	◆	◆
Rated power (kW)		◆	4.90	◆	◆	◆
R (ph-ph) (Ohms)		◆	0.08	◆	◆	◆
L (ph-ph) (mH)		◆	4.5	◆	◆	◆
Recommended power conn' size		◆	1.5	◆	◆	◆
Speed 6000 (rpm)	Kt (Nm/A) = Ke (V/krpm) =	0.47 28.5				
Rated torque (Nm)		◆	◆	◆	◆	◆
Stall current (A)		◆	◆	◆	◆	◆
Rated power (kW)		◆	◆	◆	◆	◆
R (ph-ph) (Ohms)		◆	◆	◆	◆	◆
L (ph-ph) (mH)		◆	◆	◆	◆	◆
Recommended power conn' size		◆	◆	◆	◆	◆

Motor frame size (mm)		142UD				
Voltage (Vrms)		380-480				
Frame length		A	B	C	D	E
Continuous stall torque (Nm)		10.1	17.4	25.0	31.5	38.0
Peak torque (Nm)		30.3	52.2	75.0	94.5	114.0
Standard inertia (kg cm ²)		5.6	11.0	17.0	22.1	27.2
Winding thermal time constant (sec)		235	240	245	251	256
Standard motor weight (kg)		7.40	10.10	12.74	15.39	18.04
Number of poles		10	10	10	10	10
Speed 2000 (rpm)	Kt (Nm/A) = Ke (V/krpm) =	2.4 147				
Rated torque (Nm)		8.6	15.3	21.4	◆	◆
Stall current (A)		4.21	7.25	10.42	◆	◆
Rated power (kW)		1.80	3.20	4.48	◆	◆
R (ph-ph) (Ohms)		3.90	1.53	0.79	◆	◆
L (ph-ph) (mH)		46.28	20.97	12.15	◆	◆
Recommended power conn' size		1	1	1	◆	◆
Speed 3000 (rpm)	Kt (Nm/A) = Ke (V/krpm) =	1.6 98				
Rated torque (Nm)		8.2	14.0	18.4	20.9	23.0
Stall current (A)		6.31	10.88	15.63	19.69	23.75
Rated power (kW)		2.58	4.40	5.78	6.57	7.23
R (ph-ph) (Ohms)		1.50	0.63	0.34	0.24	0.18
L (ph-ph) (mH)		18.1	8.6	5.3	3.8	2.9
Recommended power conn' size		1	1	1	1.5	1.5
Speed 4000 (rpm)	Kt (Nm/A) = Ke (V/krpm) =	1.2 74				
Rated torque (Nm)		◆	11.7	◆	14.9	◆
Stall current (A)		◆	14.50	◆	26.25	◆
Rated power (kW)		◆	4.90	◆	6.24	◆
R (ph-ph) (Ohms)		◆	0.36	◆	0.16	◆
L (ph-ph) (mH)		◆	7.1	◆	2.4	◆
Recommended power conn' size		◆	1	◆	1.5	◆
Speed 6000 (rpm)	Kt (Nm/A) = Ke (V/krpm) =	0.8 49				
Rated torque (Nm)		◆	7	◆	◆	◆
Stall current (A)		◆	21.75	◆	◆	◆
Rated power (kW)		◆	4.4	◆	◆	◆
R (ph-ph) (Ohms)		◆	0.17	◆	◆	◆
L (ph-ph) (mH)		◆	3.2	◆	◆	◆
Recommended power conn' size		◆	1.5	◆	◆	◆

◆ Not available

All data subject to +/-10% tolerance. Stall torque, rated torque and power relate to maximum continuous operation tested in a 20°C ambient at 12kHz drive switching frequency. All other figures relate to a 20°C motor temperature. Maximum intermittent winding temperature is 140°C

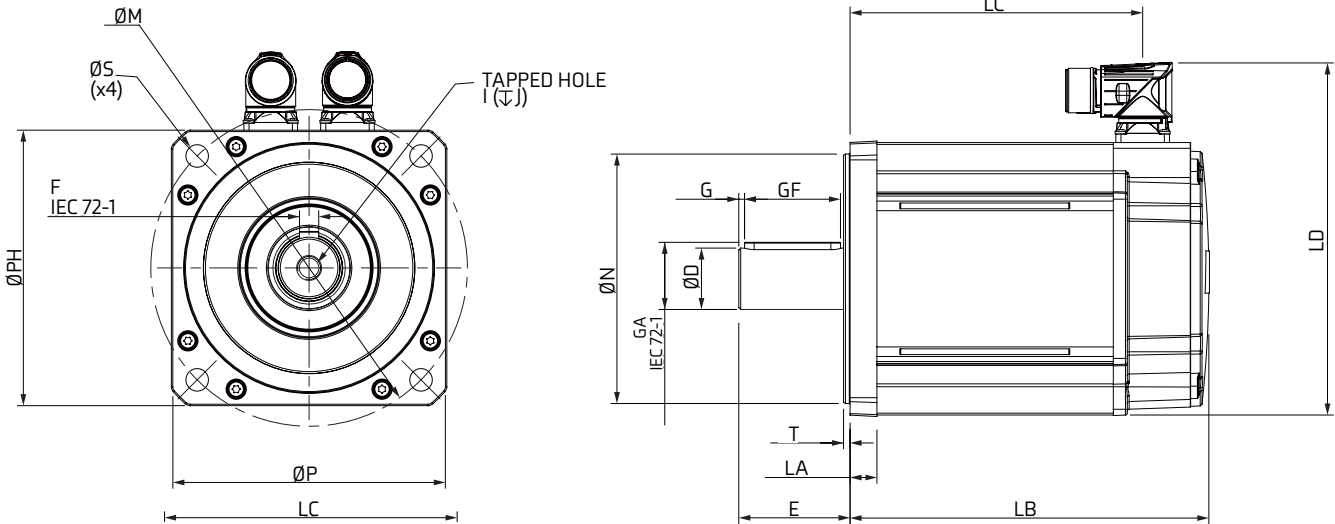

Motor Dimension													
	Unbraked length		Braked length		Flange thickness	Register length	Register diameter	Overall height	Flange square	Fixing hole diameter	Fixing hole PCD	Motor housing	Mounting bolts
	LB (± 0.9)	LC (± 1.0)	LC (± 1.0)	LC (± 1.0)	LA (± 0.5)	T (± 0.1)	N (j6)	LD (± 0.3)	P (± 0.3)	S (H14)	M (± 0.5)	PH (± 0.5)	
142A	157	122.5	222.5	188				183.5					
142B	187	152.5	252.5	218				(Size 1)					
142C	217	182.5	282.5	248	14	3.4	130	204.5	142	12	165	142	M10 mm
142D	247	212.5	312.5	278				(Size 1.5)					
142E	277	242.5	342.5	308									

Shaft Dimension									
	Shaft diameter	Shaft length	Key height	Key length	Key to shaft end	Key width	Tapped hole thread size	Tapped hole depth	
	D(j6)	E	GA	GF	G	F(h9)	I	J(±1)	
32.0 Std	32	58	35	50	3	10	M12 x 1.75	29	mm

24mm shaft and 200mm flange options are available. Refer to factory for more information.

FRAME SIZE 190

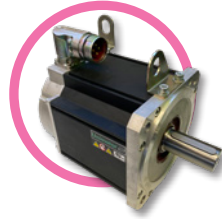

Motor frame size (mm)		190ED					
Voltage (Vrms)		200-240					
Frame length		A	B	C	D	E	F
Continuous stall torque (Nm)		18.5	32.7	52.0	62.0	73.5	85.0
Peak torque (Nm)		55.5	98.10	156	186	220.5	255
Standard inertia (kg cm ²)		22.0	38.3	54.6	70.9	87.2	103.5
Winding thermal time constant (sec)		286	292	300	308	316	324
Standard motor weight (kg)		14.60	21.20	27.74	34.30	40.90	47.42
Number of poles		10	10	10	10	10	10
Speed 1000 (rpm)	K _t (Nm/A) = K _e (V/krpm) =					2.8 171	
Rated torque (Nm)		17.6	◆	49.0	56.5	◆	77.5
Stall current (A)		6.61	◆	18.57	22.14	◆	30.36
Rated power (kW)		1.84	◆	5.13	5.92	◆	8.12
R (ph-ph) (Ohms)		1.23	◆	0.30	0.27	◆	0.15
L (ph-ph) (mH)		34.1	◆	10.0	7.1	◆	4.8
Recommended power conn' size		1.5	◆	1.5	1.5	◆	1.5
Speed 1500 (rpm)	K _t (Nm/A) = K _e (V/krpm) =					1.86 114	
Rated torque (Nm)		◆	◆	46.2	◆	◆	◆
Stall current (A)		◆	◆	25.97	◆	◆	◆
Rated power (kW)		◆	◆	7.26	◆	◆	◆
R (ph-ph) (Ohms)		◆	◆	0.11	◆	◆	◆
L (ph-ph) (mH)		◆	◆	3.5	◆	◆	◆
Recommended power conn' size		◆	◆	1.5	◆	◆	◆
Speed 2000 (rpm)	K _t (Nm/A) = K _e (V/krpm) =					1.4 85.5	
Rated torque (Nm)		◆	◆	42.5	◆	◆	◆
Stall current (A)		◆	◆	37.14	◆	◆	◆
Rated power (kW)		◆	◆	8.9	◆	◆	◆
R (ph-ph) (Ohms)		◆	◆	0.09	◆	◆	◆
L (ph-ph) (mH)		◆	◆	2.5	◆	◆	◆
Recommended power conn' size		◆	◆	1.5	◆	◆	◆
Speed 3000 (rpm)	K _t (Nm/A) = K _e (V/krpm) =					0.93 57	
Rated torque (Nm)		15.5	25.0	32.8	◆	◆	◆
Stall current (A)		19.89	35.16	55.91	◆	◆	◆
Rated power (kW)		4.87	7.85	10.30	◆	◆	◆
R (ph-ph) (Ohms)		0.20	0.05	0.03	◆	◆	◆
L (ph-ph) (mH)		3.1	1.6	1.2	◆	◆	◆
Recommended power conn' size		1.5	1.5	1.5	◆	◆	◆

Motor frame size (mm)		190UD					
Voltage (Vrms)		380-480					
Frame length		A	B	C	D	E	F
Continuous stall torque (Nm)		18.5	32.7	52.0	62.0	73.5	85.0
Peak torque (Nm)		55.5	98.10	156	186	220.5	255
Standard inertia (kg cm ²)		22.0	38.3	54.6	70.9	87.2	103.5
Winding thermal time constant (sec)		286	292	300	308	316	324
Standard motor weight (kg)		14.60	21.20	27.74	34.30	40.90	47.42
Number of poles		10	10	10	10	10	10
Speed 1000 (rpm)	K _t (Nm/A) = K _e (V/krpm) =					4.8 296	
Rated torque (Nm)		17.6	◆	◆	◆	◆	78.3
Stall current (A)		3.83	◆	◆	◆	◆	17.61
Rated power (kW)		1.83	◆	◆	◆	◆	8.12
R (ph-ph) (Ohms)		3.70	◆	◆	◆	◆	0.53
L (ph-ph) (mH)		101.4	◆	◆	◆	◆	15.8
Recommended power conn' size		1.5	◆	◆	◆	◆	1.5
Speed 1500 (rpm)	K _t (Nm/A) = K _e (V/krpm) =					3.2 196	
Rated torque (Nm)		◆	◆	46.2	◆	◆	68.5
Stall current (A)		◆	◆	16.25	◆	◆	26.56
Rated power (kW)		◆	◆	7.26	◆	◆	10.76
R (ph-ph) (Ohms)		◆	◆	0.55	◆	◆	0.23
L (ph-ph) (mH)		◆	◆	14.2	◆	◆	6.8
Recommended power conn' size		◆	◆	1.5	◆	◆	1.5
Speed 2000 (rpm)	K _t (Nm/A) = K _e (V/krpm) =					2.4 147	
Rated torque (Nm)		◆	◆	42.5	45.3	52.9	56
Stall current (A)		◆	◆	21.67	25.83	30.63	35.42
Rated power (kW)		◆	◆	8.90	9.49	11.08	11.73
R (ph-ph) (Ohms)		◆	◆	0.32	0.17	0.16	0.14
L (ph-ph) (mH)		◆	◆	8.2	5.1	4.6	4.3
Recommended power conn' size		◆	◆	1.5	1.5	1.5	1.5
Speed 3000 (rpm)	K _t (Nm/A) = K _e (V/krpm) =					1.6 98	
Rated torque (Nm)		15.5	25.0	32.8	39.0	◆	◆
Stall current (A)		11.56	20.44	32.50	38.75	◆	◆
Rated power (kW)		4.87	7.85	10.30	12.25	◆	◆
R (ph-ph) (Ohms)		0.57	0.23	0.11	0.11	◆	◆
L (ph-ph) (mH)		11.6	5.7	3.1	2.7	◆	◆
Recommended power conn' size		1.5	1.5	1.5	1.5	◆	◆

◆ Not available

All data subject to +/-10% tolerance. Stall torque, rated torque and power relate to maximum continuous operation tested in a 20°C ambient at 12kHz drive switching frequency. All other figures relate to a 20°C motor temperature. Maximum intermittent winding temperature is 140°C

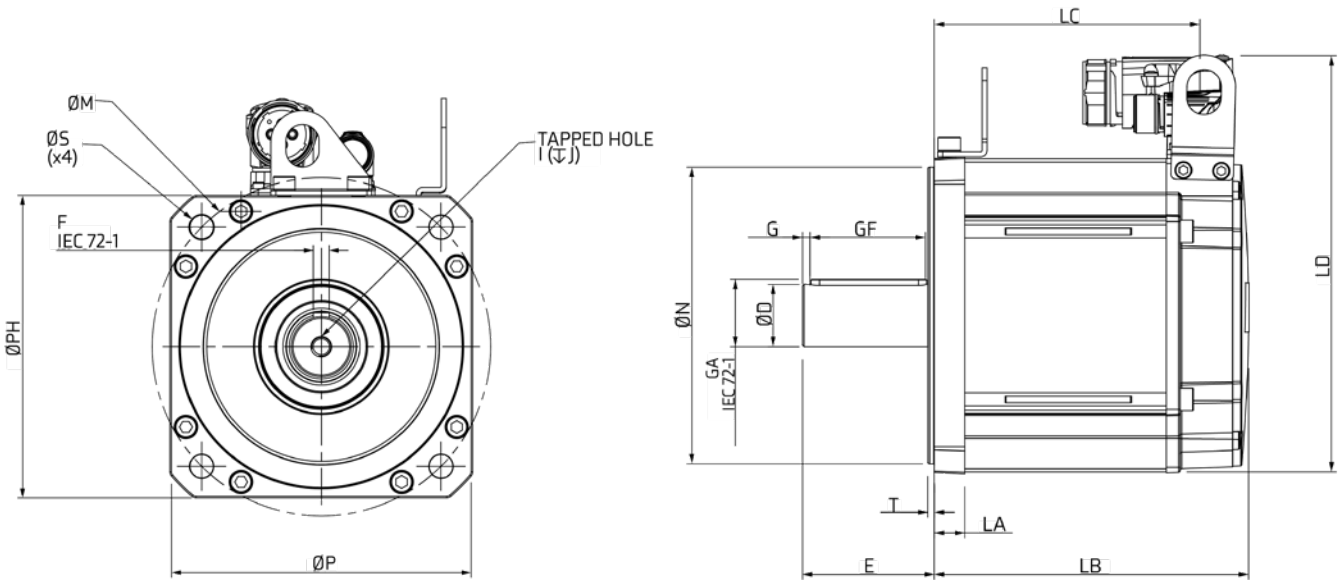

Motor Dimension													
	Unbraked length	Braked length		Flange thickness	Register length	Register diameter	Overall height	Flange square	Fixing hole diameter	Fixing hole PCD	Motor housing	Mounting bolts	
	LB (±0.9)	LC (±1.0)	LC (±1.0)	LC (±1.0)	LA (±0.5)	T (±0.1)	N (j6)	LD (±0.3)	P (±0.3)	S (H14)	M (±0.5)	PH (±0.5)	
190A	160.6	131.1	259.1	229.6									
190B	190.6	161.1	289.1	259.6									
190C	220.6	191.1	319.1	289.6									
190D	250.6	221.1	349.1	319.6	18.5	3.9	180	252.5	190.3	14.5	215	190	M12 mm
190E	280.6	251.1	379.1	349.6									
190F	310.6	281.1	409.1	379.6									

Shaft Dimension									
	Shaft diameter	Shaft length	Key height	Key length	Key to shaft end	Key width	Tapped hole thread size	Tapped hole depth	
	D(j6)	E	GA	GF	G	F(h9)	I	J(±1)	
	38.0 Std	38	80	41	70	4.6	10	M12 x 1.75	29 mm

42mm shaft and 235mm flange options are available. Refer to factory for more information.

Dimensions - high inertia version

(all measurements shown are in mm)

067	Unbraked length		Braked length		Flange thickness	Register length	Register diameter	Overall height	Flange square	Fixing hole diameter	Fixing hole PCD	Motor housing	Mounting bolts
	LB (± 0.9)	LC (± 1.0)	LB (± 0.9)	LC (± 1.0)									
A	172.9	139.0	207.9	174.0	7.7	2.5	60.0	111.5	70.0	5.8	75.0	67.0	M5
B	202.9	169.0	237.9	204.0									
C	232.9	199.0	267.9	234.0									
D	262.9	229.0	297.9	264.0									
089	Feedback EC, FC, EF, FF				Flange thickness	Register length	Register diameter	Overall height	Flange square	Fixing hole diameter	Fixing hole PCD	Motor housing	Mounting bolts
	Unbraked length		Braked length										
A	177.8	140.5	217.9	180.6	10.3	2.2	80.0	130.5	91.0	7.0	100.0	89.0	M6
B	207.8	170.5	247.9	210.6									
C	237.8	200.5	277.9	240.6									
D	267.8	230.5	300.9	270.6									
	CA, CT, GB, HB		AE		Flange thickness	Register length	Register diameter	Overall height	Flange square	Fixing hole diameter	Fixing hole PCD	Motor housing	Mounting bolts
	Unbraked	Braked	Unbraked	Braked									
A	190.8	230.9	167.8	207.9	10.3	2.2	80.0	130.5	91.0	7.0	100.0	89.0	M6
B	220.8	260.9	197.8	237.9									
C	250.8	290.9	227.8	267.9									
D	280.8	320.9	257.8	297.9									
115	Feedback EC, FC, EF, FF				Flange thickness	Register length	Register diameter	Overall height	Flange square	Fixing hole diameter	Fixing hole PCD	Motor housing	Mounting bolts
	Unbraked length		Braked length										
A	193.8	154.0	230.9	191.1	13.2	2.7	110.0	156.5	116.0	10.0	130.0	115.0	M8
B	223.8	184.0	260.9	221.1									
C	253.8	214.0	290.9	251.1									
D	283.8	244.0	320.9	281.1									
	CA, CT, GB, HB		AE		Flange thickness	Register length	Register diameter	Overall height	Flange square	Fixing hole diameter	Fixing hole PCD	Motor housing	Mounting bolts
	Unbraked	Braked	Unbraked	Braked									
A	206.8	243.9	183.8	220.9	13.2	2.7	110.0	156.5	116.0	10.0	130.0	115.0	M8
B	236.8	273.9	213.8	250.9									
C	266.8	303.9	243.8	280.9									
D	296.8	333.9	273.8	310.9									
142	Unbraked length		Braked length		Flange thickness	Register length	Register diameter	Overall height	Flange square	Fixing hole diameter	Fixing hole PCD	Motor housing	Mounting bolts
	LB (± 0.9)	LC (± 1.0)	LB (± 0.9)	LC (± 1.0)									
A	187.0	152.5	252.5	218.0	14.0	3.4	130.0	183.5	142.0	12.0	165.0	142.0	M10
B	217.0	182.5	282.5	248.0				(Size 1)					
C	247.0	212.5	312.5	278.0				204.5					
D	277.0	242.5	342.5	308.0				(Size 1.5)					
E	307.0	272.5	372.5	338.0									
190	Unbraked length		Braked length		Flange thickness	Register length	Register diameter	Overall height	Flange square	Fixing hole diameter	Fixing hole PCD	Motor housing	Mounting bolts
	LB (± 0.9)	LC (± 1.0)	LB (± 0.9)	LC (± 1.0)									
A	190.6	161.1	289.1	259.6	18.5	3.9	180.0	252.5	190.3	14.5	215.0	190.0	M12
B	220.6	191.1	319.1	289.6									
C	250.6	221.1	349.1	319.6									
D	280.6	251.1	379.1	349.6									
E	310.6	281.1	409.1	379.6									
F	340.6	311.1	439.1	409.6									

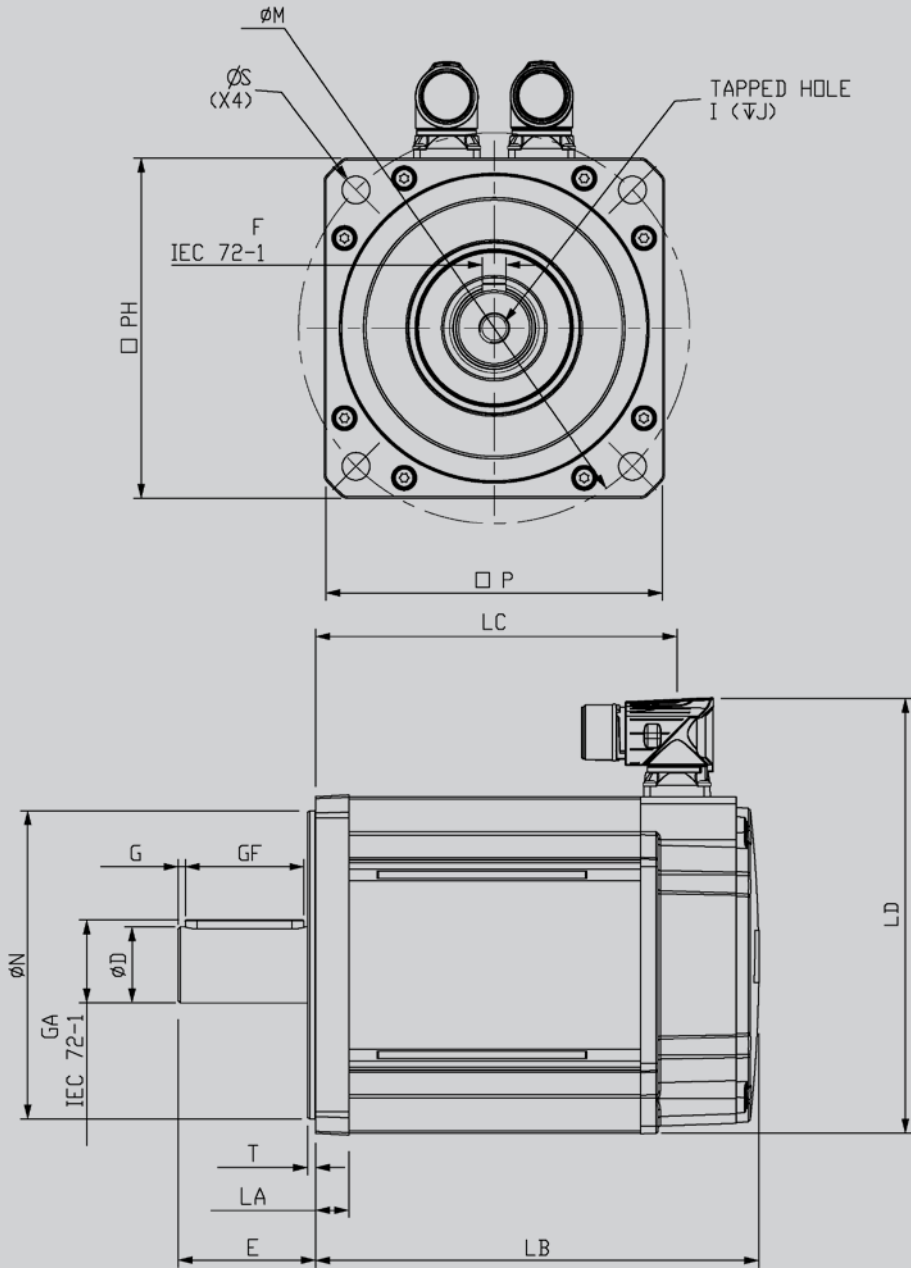

	Shaft diameter	Shaft length	Key height	Key length	Key to shaft end	Key width	Tapped hole thread size	Tapped hole depth
	D (j6)	E	GA	GF	G	F (h9)	I	J (± 1)
067	14.0	30.0	16.0	25.0	1.5	5.0	M5 x 0.8	13.5
089	19.0	40.0	21.5	32.0	3.7	6.0	M6 x 1.0	17.0
115	24.0	50.0	27.0	40.0	5.3	8.0	M8 x 1.25	20.0
142	32.0	58.0	35.0	50.0	3.0	10.0	M12 x 1.75	29.0
190	38.0	80.0	41.0	70.0	4.6	10.0	M12 x 1.75	29.0

NOTE: motor drawing is for dimensional purposes only, motors will differ in appearance.

PERFORMANCE DEFINITIONS



Stall torque

This is the maximum torque within the continuous zone at zero speed. Maximum continuous torque ratings may be intermittently exceeded for short periods provided that the winding Δt max temperature is not exceeded.

Δt max = 100 °C over a maximum ambient of 40 °C for Unimotor hd.

Stall current

Stall current = Stall torque / k_t

Motor label and performance tables quote stall current when motor is at full power in a maximum ambient of 40 °C.

Rated speed

This is the maximum speed of the motor within the continuous zone. The motor speed can be controlled to any speed subject to the voltage limits and drive constraints as shown by the intermittent zone on a motor performance graph.

Ke voltage constant

This is the phase to phase rms voltage generated at the stator when the shaft is back driven at 1,000 rpm with the rotor at 20 °C.

Kt torque constant

A brushless motor delivers torque proportional to the current, such that torque = $K_t \times$ current.

Where $K_t = 0.0165 \times K_e$ (at 20 °C).

Magnets used on all motors are affected by temperature such that K_e and K_t reduce with increasing temperatures of the magnets.

Winding thermal time constant

The thermal time constant of the winding with respect to the stator temperature as a reference in the exponential temperature rise given by the formula:

Winding temperature at time t seconds = $T_0 + T_1(1 - e^{-t/t_c})$

Where T_0 is the initial temperature, T_1 is the final winding temperature and t_c = thermal time constant (seconds)

Note that temperature = 63.2 % of T_1 when $t = t_c$. A thermal protection trip is provided by the drive, based upon calculations using elapsed time, current measurement, and the parameter settings set by the user or directly from the motor map.

Unimotor hd windings are ultimately protected by thermistor devices in the winding overhangs. These must be connected to the appropriate drive inputs via the motor feedback signal connector.

Rated power

This is the product of the rated speed (radian/sec) and the rated torque (Nm) expressed in Watts (W)

Δt temperature

Δt temperature is the temperature difference between the copper wires of the motor winding and the ambient air temperature surrounding the motor.

The maximum Δt temperature permitted is 100 °C over a maximum ambient of 40 °C. (i.e. a maximum winding temperature of 140 °C)



NAMEPLATE DEFINITIONS

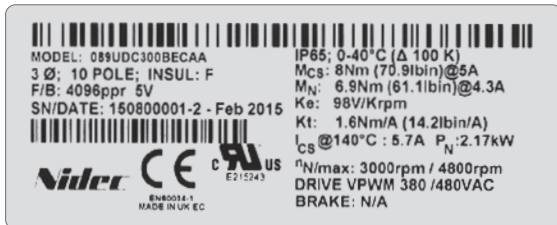

Model Full part number of the motor

3Ø Indicates this is a 3 phase motor

POLE Number of poles:
060-190 – 10 poles – 5 pole pairs

Insul Windings are built to class F (155 °C)

F/B This gives the feedback device, count and working voltage or the feedback type

S/N/DATE The serial number and date the motor was manufactured

IP Ingress protection rating IP 655

M_{cs} The stall torque at stall current

M_n The rated torque of the motor

K_e This is the AC Volts per 1,000 rpm with the motor at 20 °C

K_t Value shown is for the magnet's temperature at 20 °C

I_{cs} The constant stall current at the maximum winding temperature of 140 °C

P_n The rated power of the motor

n_N/max The rated speed/ this is the maximum speed allowed when taking into account these three factors:

- Max drive voltage
- Max encoder speed
- Max mechanical speed

VPWM This indicates that the motor is for use with a voltage pulse width modulated drive with the supply voltage shown

Brake The current, that rated torque and the operation voltage for the brake or N/A if the brake is not fitted

Electronic namplate available.
Refer to factory for more information.

UNIMOTOR HD MOTOR DERATING

Ambient temperatures

The ambient temperature around the motor must be taken into account. For ambient temperatures above 40 °C the torque must be derated using the following formula as a guideline. (Note: Only applies to 2,000/3,000 rpm motors and assumes copper losses dominate.)

$$\text{New derated torque} = \text{Specified torque} \times \sqrt{1 - ((\text{Ambient temperature} - 40^\circ\text{C}) / 100)}$$

For example with an ambient temperature of 76 °C the new derated torque will be 0.8 x specified value

Thermal test conditions

The performance data shown has been recorded under the following conditions. Ambient temperature 20°C, with the motor mounted on a thermally isolated aluminium plate as shown below.

Mounting arrangements

The motor torque must be derated if:

- The motor mounting surface is heated from an external source, such as a gearbox.
- The motor is connected to a poor thermal conductor.
- The motor is in a confined space with restricted air flow.

Unimotor hd derate factors

Switching frequency	060	067	089	115	142	190
3kHz	n/a	0.93	0.89	0.89	0.83	0.9
4kHz	n/a	0.94	0.91	0.92	0.85	0.95
6kHz	n/a	0.95	0.95	0.96	0.88	1
8kHz	0.99	0.98	0.97	0.98	0.91	1
12/16kHz	1	1	1	1	1	1

NOTE: Only applies to motors up to 3,000 rpm (rms) or lower. Assumes copper losses dominate on all frame sizes. Derate factor is applied to stall torque, rated torque, stall current and rated power.

UNIMOTOR HD BRAKE SPECIFICATION

Unimotor hd may be ordered with an internal rear mounted spring applied parking brake. The brake works on a failsafe principle. The brake is active when the supply voltage is switched off, and the brake is released when the supply voltage is switched on.

If a motor is fitted with a failsafe brake, take care not to subject the motor shaft to excessive torsional shocks or resonance when the brake is engaged or disengaged. Doing so can damage the brake.

Safety note

The failsafe brake is for use as a holding brake with the motor shaft stationary. Do NOT use it as a dynamic brake. Using it in this manner will cause brake wear and eventual failure. Emergency Stop situations can contribute to brake wear and failure.

Unimotor hd

Motor frame	Supply volts	Input power	Static torque @ 120 °C Parking Brake '5'	Release time	Moment of inertia	Backlash *
Size	Vdc	Watts	Nm	ms nom.	kg.cm ²	Degrees *
060	24	7.2	1.3	50	0.02	0.80
142 (C-E)	24	25	38	95	1.85	0.77
190 (A-D)	24	25	60	120	4.95	0.77
190 (E-F)	24	54.5	90	250	7.72	0.75

Motor frame	Supply volts	Input power @ 20 °C	Static torque @ 120 °C Parking Brake '6'	Release time	Moment of inertia	Backlash *
Size	Vdc	Watts	Nm	ms nom.	kg.cm ²	Degrees *
067	24	15	2	35.2	0.063	0.62°
089	24	18.5	10	72.8	0.259	0.45°
115	24	17.5	16	64	0.506	0.38°
142 (A-B)	24	17.5	16	64	0.506	0.38°

- * Backlash figure will increase with time
- The brake is intended for parking duty and is not for dynamic or safety use.
- Refer to your Automation Center or Distributor if your application requires dynamic braking in emergency conditions.
- To provide protection to the brake control circuit it is recommended that a diode is connected across the output terminals of the solid state or relay contacts devices.
- Larger torque brakes are available as an option. Contact your Automation Center or Distributor for details.
- Unless otherwise stated, all figures are representative at 20 °C brake temperature.
- The brake will engage when power is removed.
- Multiply static torque value by 1.1x for minimum holding torque at 20-100°C

It is recommended to run extensive application validation testing and confirm the motor brake life span when the motor is mounted vertically and the motor runs through high acceleration and deceleration.

Additional motor weights all figures are subject to a tolerance of (±10%)

Motor frame size	060	067	089	115	142	142	190
Frame length	A to C	A to D	A to D	A to D	A to B	C to E	A to F
Braked '5' brake	+0.28kg					+2.8kg	+4.0kg
Braked '6' brake		+0.68kg	+1.4kg	+2.09kg	+2.29kg		
Fan box				+1.65kg	+1.9kg	+1.9kg	+2.6kg
Hybrid box small				+0.5kg	+0.5kg	+0.5kg	
Hybrid box medium					+0.5kg	+0.5kg	+0.5kg
Hybrid box large							+1.5kg

Feedback

Feedback device order code	Feedback type	Manufacturer	Encoder supply voltage	SinCos cycle or incremental pulses per revolution	Resolution available to position loop ^{2,3}	Absolute multi-turn revolutions	Feedback accuracy ¹	Single cable connector available ⁴	Serial communication protocol
060 - 190 motors (refer to order codes page 6)									
CT	Incremental Encoder	NMC	5 Vdc ± 10%	4096	Medium 16384 (14 bits)	-	Low +/- 720"	-	-
060 - 067 motors (refer to order codes page 6)									
AR	Resolver	LTN RE - 15	7 Vdc Excitation 5kHz	1 Transformation ratio 0.5	Medium 16384 (14 bits)	-	Low +/- 600"	-	-
CR	Incremental Encoder	R35i	5 Vdc ± 10%	4096	Medium 16384 (14 bits)	-	Medium +/- 150"	-	-
EM (Multi-turn)	Inductive EnDat SinCos	EQI 1130	4.75 - 10 Vdc	16	High 2.62 x 14 ⁴ (18 bits)	4096 (12 bits)	Medium +/- 280"	-	EnDat 2.1 / EnDat 01
FM (Single-turn)		ECI 1118							
EG (Multi-turn)	Inductive EnDat Only	EQI 1131	3.6 - 14 Vdc	N/A	High 5.24 x 10 ⁵ (19 bits)	4096 (12 bits)	Medium +/- 120"	6 wire HMC6	EnDat 2.2 / EnDat 22
FG (Single-turn)		ECI 1119							
Functional safety capable SIL2 rated (SIL3 with option code)									
089 - 190 motors									
AE	Resolver	Size 52	6 Vdc Excitation 6kHz	1 Transformation ratio 0.31	Medium 16384 (14 bits)	-	Low +/- 720"	-	-
CA	Incremental Encoder	CF550	5 Vdc ± 10%	4096	Medium 16384 (14 bits)	-	High +/- 60"	-	-
EC (Multi-turn)	Inductive EnDat SinCos	EQI 1331	4.75 - 10 Vdc	32	High 5.24 x 10 ⁵ (19 bits)	4096 (12 bits)	Medium +/- 380"	-	EnDat 2.1 / EnDat 01
FC (Single-turn)		ECI 1319							
EF (Multi-turn)	Inductive EnDat Functional Safety	EQI 1331 FS	3.6 - 14 Vdc	Serial Only	High 5.24 x 10 ⁵ (19 bits)	4096 (12 bits)	High +/- 65"	6 wire HMC6	EnDat 2.2 / EnDat 22
FF (Single-turn)		ECI 1319 FS							
Functional safety capable SIL2 rated (SIL3 with option code)									
GB (Multi-turn)	Optical EnDat Only	EQN 1337	3.6 - 14 Vdc	N/A	Very High 3.35 x 10 ⁷ (25 bits)	4096 (12 bits)	Very High +/- 20"	6 wire HMC6	EnDat 2.2 / EnDat 22
HB (Single-turn)		ECN 1325							

¹ The information is supplied by the feedback device manufacturer and relates to it as a standalone device.

² The output from the resolver is an analogue output; the resolution is determined by the analogue to digital converter used.

³ The sin and cosine outputs from the SinCos optical encoders are analogue outputs; with Unidrive M and Digitax ST the resolutions quoted above are when the encoder type is set to either SC EnDat or SC Hiperface depending on the encoder.

⁴ To be ordered with single cable connector, see connector options. 6 wire HMC6 must be ordered with KTY 84-130 thermistor, see inertia options.

POWER PLUG - Motor end

Size 1 - Type B			Size 1.5 - Type J Connector		
	With brake	Without brake		With brake	Without brake
Pin	Function	Function	Pin	Function	Function
1	Phase U (R)	Phase U (R)	U	Phase U (R)	Phase U (R)
2	Phase V (S)	Phase V (S)	V	Phase V (S)	Phase V (S)
3	Ground	Ground	⊕	Ground	Ground
4	Phase W (T)	Phase W (T)	W	Phase W (T)	Phase W (T)
5	Brake		+	Brake	
6	Brake		-	Brake	
Shell	Screen	Screen	Shell	Screen	Screen

SIGNAL PLUG - Motor end

SI		SE		SR
	Incremental encoder (CA, CT, CR)	Heidenhain Sincos EnDat 2.1 absolute encoders (EM, FM, EC, FC)	Heidenhain EnDat 2.2 only absolute encoders (EF, FF, EG, FG, GB, HB)	Resolver (AE, AR)
Pin	Function	Function	Function	Function
1	Thermistor	Thermistor	Thermistor	Excitation High
2	Thermistor	Thermistor	Thermistor	Excitation Low
3		Screen (Optical only)	Screen (Optical only)	Cos High
4	S1			Cos Low
5	S1 Inverse			Sin High
6	S2			Sin Low
7	S2 Inverse			Thermistor
8	S3	+ Clock	+ Clock	Thermistor
9	S3 Inverse	- Clock	- Clock	
10	Channel A	+ Cos		
11	Index	+ Data	+ Data	
12	Index Inverse	- Data	- Data	
13	Channel A Inverse	- Cos		
14	Channel B	+ Sin		
15	Channel B Inverse	- Sin		
16	+V	+V	+V	
17	0 Volts	0 Volts	0 Volts	
Body	Screen	Screen	Screen	

POWER & SIGNAL COMBINED PLUG - Motor end

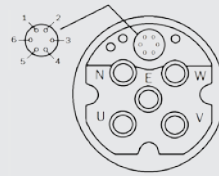
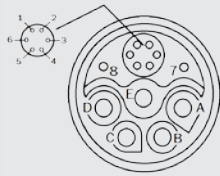

Size 1 - Type D Connector & Type S Connector

Size 1.5 - Type E Connector

Heidenhain EnDat 2.2 only absolute encoders
(EF, FF, EG, FG, GB, HB)

Heidenhain EnDat 2.2 only absolute encoders
(EF, FF, GB, HB)

Pin	Size 1 - Type D Connector & Type S Connector		Pin	Size 1.5 - Type E Connector	
	With brake	Without brake		With brake	Without brake
1	+ Volts	+ Volts	1	+ Volts	+ Volts
2	0 Volts	0 Volts	2	0 Volts	0 Volts
3	+ Data	+ Data	3	+ Data	+ Data
4	- Data	- Data	4	- Data	- Data
5	+ Clock	+ Clock	5	+ Clock	+ Clock
6	- Clock	- Clock	6	- Clock	- Clock
7	- Brake	-	N	-	-
8	+ Brake	-	U	Phase U (R)	Phase U (R)
A	Phase U (R)	Phase U (R)	V	Phase V (S)	Phase V (S)
B	Phase V (S)	Phase V (S)	PE	Ground	Ground
C	Phase W (T)	Phase W (T)	W	Phase W (T)	Phase W (T)
D	-	-	+	Brake	-
E	Ground	Ground	-	Brake	-

15 WAY PLUG - Drive end



Pin	SI		SE	SR
	Incremental encoders (CA, CT, CR)	SinCos absolute encoders (EM, FM, EC, FC)	EnDat 2.2 only absolute encoders (EF, FF, EG, FG, GB, HB)	Resolvers (AE, AR)
1	Channel A	+ Cos	+ Data	+ Cos
2	Channel A Inverse	- Cos	- Data	- Cos
3	Channel B	+ Sin	+ Clock	+ Sin
4	Channel B Inverse	- Sin	- Clock	- Sin
5	Index	+ Data	-	+ Excitation
6	Index Inverse	- Data	-	- Excitation
7	S1	-	-	-
8	S1 Inverse	-	-	-
9	S2	-	-	-
10	S2 Inverse	-	-	-
11	S3	+ Clock	-	-
12	S3 Inverse	- Clock	-	-
13	+V	+V	+V	-
14	0 Volts	0 Volts	0 Volts	Thermistor
15	Thermistor	Thermistor	Thermistor	Thermistor
Body	Screen	Screen	Screen	Screen

Y-TEC SIGNAL/POWER PLUG - Motor end

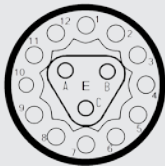

Signal - Type T Connector (CT)			Power - Type T connector		
Pin	Function	Pin	With brake Function	Without brake Function	
1	Ground	A	Phase U	Phase U	
2	Channel A	B	Phase V	Phase V	
3	Channel A Inverse	C	Phase W	Phase W	
4	Channel B	1	Thermistor +	Thermistor +	
5	Channel B Inverse	2	Thermistor -	Thermistor -	
6	+ V	3	+ V		
7	S1	4	0 Volts		
8	S2	⊕	Ground	Ground	
9	S3				
10	S1 Inverse				
11	S2 Inverse				
12	S3 Inverse				
A	Index				
B	Index Inverse				
C	-				

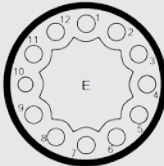
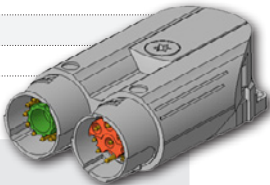

Signal - Type T Connector				
Pin	(EG / FG) Function	(TL / UL) Function	Resolver Function	
1	+ V	+ V	-	
2	+ Data	+ Data	-	
3	- Data	- Data	-	
4	+ Clock	-	-	
5	- Clock	-	-	
6	-	-	Excitation Low	
7	0 Volts	0 Volts	-	
8	-	+ Sin	Sin High	
9	-	REF Sin	Sin Low	
10	-	+ Cos	Cos High	
11	-	REF Cos	Cos Low	
12	-	-	Excitation High	



8 WAYPOWER PLUG - Motor end

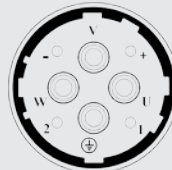

Size 1 - Type R Connector

Size 1.5 - Type Z Connector

Pin	Size 1 - Type R Connector		Pin	Size 1.5 - Type Z Connector	
	With brake	Without brake		With brake	Without brake
1	Phase U (R)	Phase U (R)	U	Phase U (R)	Phase U (R)
2	Ground	Ground	V	Phase V (S)	Phase V (S)
3	Phase W (T)	Phase W (T)	⊖	Ground	Ground
4	Phase V (S)	Phase V (S)	W	Phase W (T)	Phase W (T)
A	Thermistor	Thermistor	+	Brake	
B	Thermistor	Thermistor	-	Brake	
C	Brake		1	Thermistor	Thermistor
D	Brake		2	Thermistor	Thermistor
Shell	Screen	Screen	Shell	Screen	Screen

PERFECT COMBINATIONS

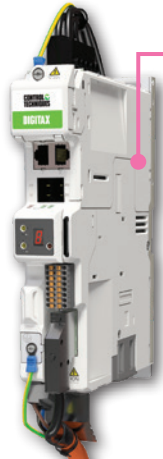

Digitax HD

Optimised for high-dynamic applications, Digitax HD provides the flexibility of both standalone and modular configurations. The drive offers full servo control plus open loop permanent magnet and induction motor control across four functionality levels: EtherCAT, MCI machine control, multiprotocol Ethernet and the flexible Base drive.

For motors below 16A continuous stall current.

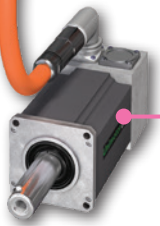

Unimotor hd

Unimotor hd is Control Techniques' high dynamic brushless AC servo motor range. With high peak torque, low inertia and the most compact dimensions, Unimotor hd is optimized for applications requiring rapid acceleration and deceleration.

Unidrive M700

Unidrive M700 series provides high performance motor control and ultimate control flexibility in order to satisfy the requirements of machine builders and high specification industrial and hoisting applications.

For motors 16A and above continuous stall current

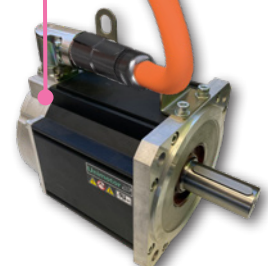

Please refer to the Digitax HD and Unidrive M brochures for more detailed information.

DRIVE OBSESSED



Control Techniques has been designing and manufacturing the best variable speed drives in the world since 1973.

Our customers reward our commitment to building drives that outperform the market. They trust us to deliver on time every time with our trademark outstanding service.

More than 45 years later, we're still in pursuit of the best motor control, reliability and energy efficiency you can build into a drive. That's what we promise to deliver, today and always.

1.5K+

Employees

70

Countries

#1 FOR ADVANCED MOTOR AND DRIVE TECHNOLOGY



Nidec Corporation is a global manufacturer of electric motors and drives.

Nidec was set up in 1973. The company made small precision AC motors and had four employees. Today, it's a global corporation that develops, builds and installs cutting-edge drives, motors and control systems in over 70 countries with a workforce of more than 110,000.

You'll find its innovations in thousands of industrial plants, IoT products, home appliances, cars, robotics, mobile phones, haptic devices, medical apparatus and IT equipment all over the world.

112K

Employees

\$14.2B

Group Turnover

44+

Countries

337+

Companies



CONTROL TECHNIQUES.
NO ONE KNOWS DRIVES LIKE WE DO.

Our drive obsessive representatives will drive you in the right direction and give you first class support whenever you need it.

For more information, or to find your local drive centre, visit:

Connect with us



©2022 Nidec Control Techniques Limited. The information contained in this brochure is for guidance only and does not form part of any contract. The accuracy cannot be guaranteed as Nidec Control Techniques Ltd have an ongoing process of development and reserve the right to change the specification of their products without notice.

Nidec Control Techniques Limited. Registered Office: The Gro, Newtown, Powys SY16 3BE.

Registered in England and Wales. Company Reg. No. 01236886.

P.N.0781-0725-02 01/22

