

TECHNICAL DATA

Three Phase Electric Motors - Cast Iron Frame
 UM3C 225M-2 IE3
 45 kW / 60 Cv
 2970 RPM

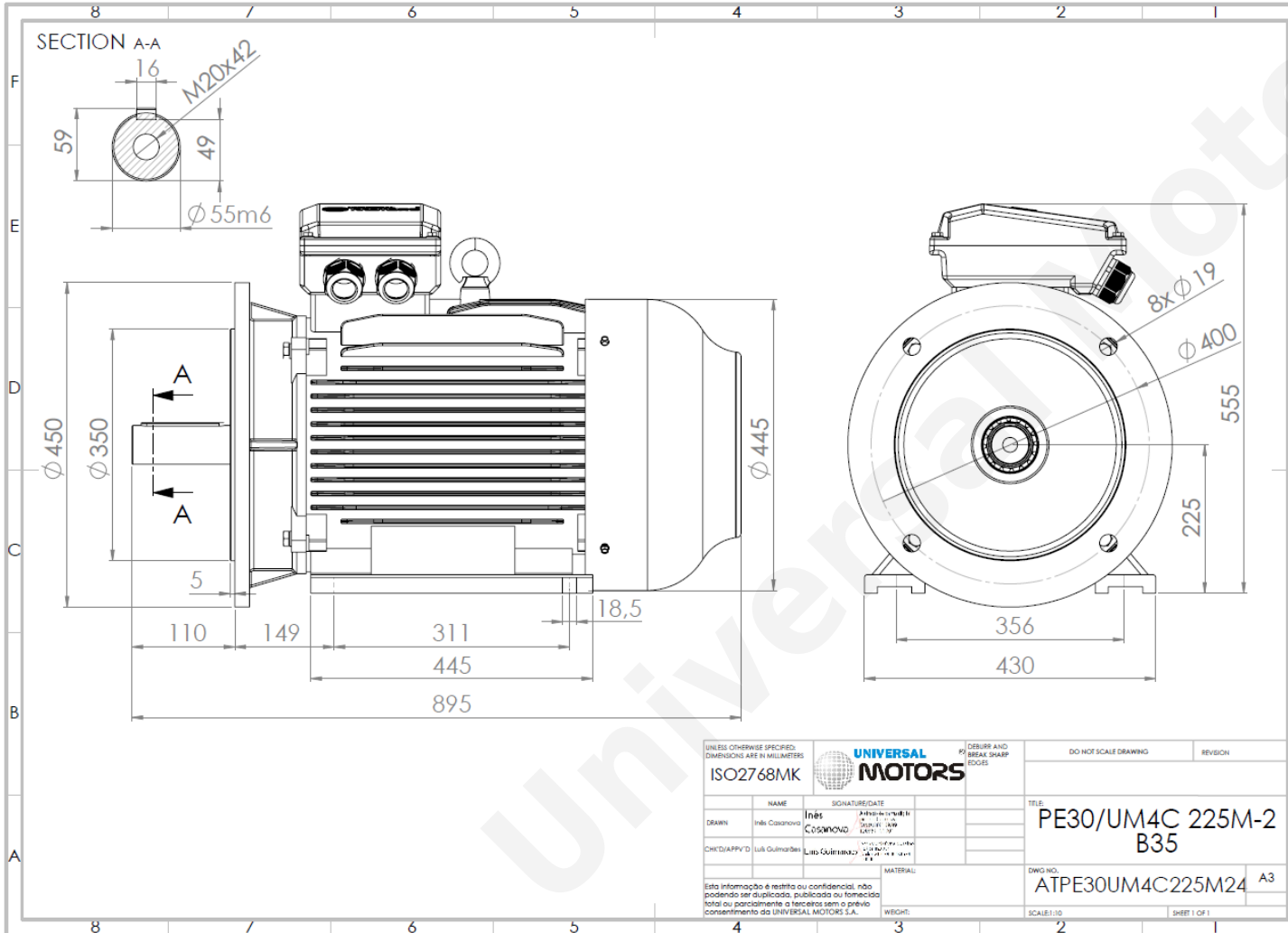

Motor type:	UM3C 225M-2 IE3
Output:	45 kW / 60 Cv
Speed (min ⁻¹):	2970 RPM
Voltage:	400 V
Frequency:	50 Hz
Current:	76.8 A
Power factor (Cos ϕ):	0.90
Poles:	2
Insulation class:	F
Temperature rise Class:	B
Efficiency 50%:	92.7 %
Efficiency 75%:	94.0 %
Efficiency 100%:	94.1 %
Torque:	145 N.m
Tstarting/Tnominal:	2.0
Istarting/Inominal:	7.7
Tmaximum/Tnominal:	2.3
Noise:	86 Db(A)
Weight:	359 Kg
Bearing DE:	6313 C3
Bearing NDE:	6313 C3

Regime - S1

Altitude - 1000m

Environment Temperature - 40°C

CONTACTS:

Universal Motors UK, Ltd
 Unit E2, Meltham Mills Industrial Estate, Meltham Mills Road, Meltham, Holmfirth
 West Yorkshire HD9 4AR, U.K

Tel: +44(0) 1484 660 222
 Fax: +44(0) 1484 660 333
 Mail: enquiries@universalmotors-group.co.uk

* References applied only in the UK