

TECHNICAL DATA

Three Phase Electric Motors - Cast Iron Frame
 UM3C 160MX-8 IE3
 5.5 kW / 7.5 Cv
 720 RPM

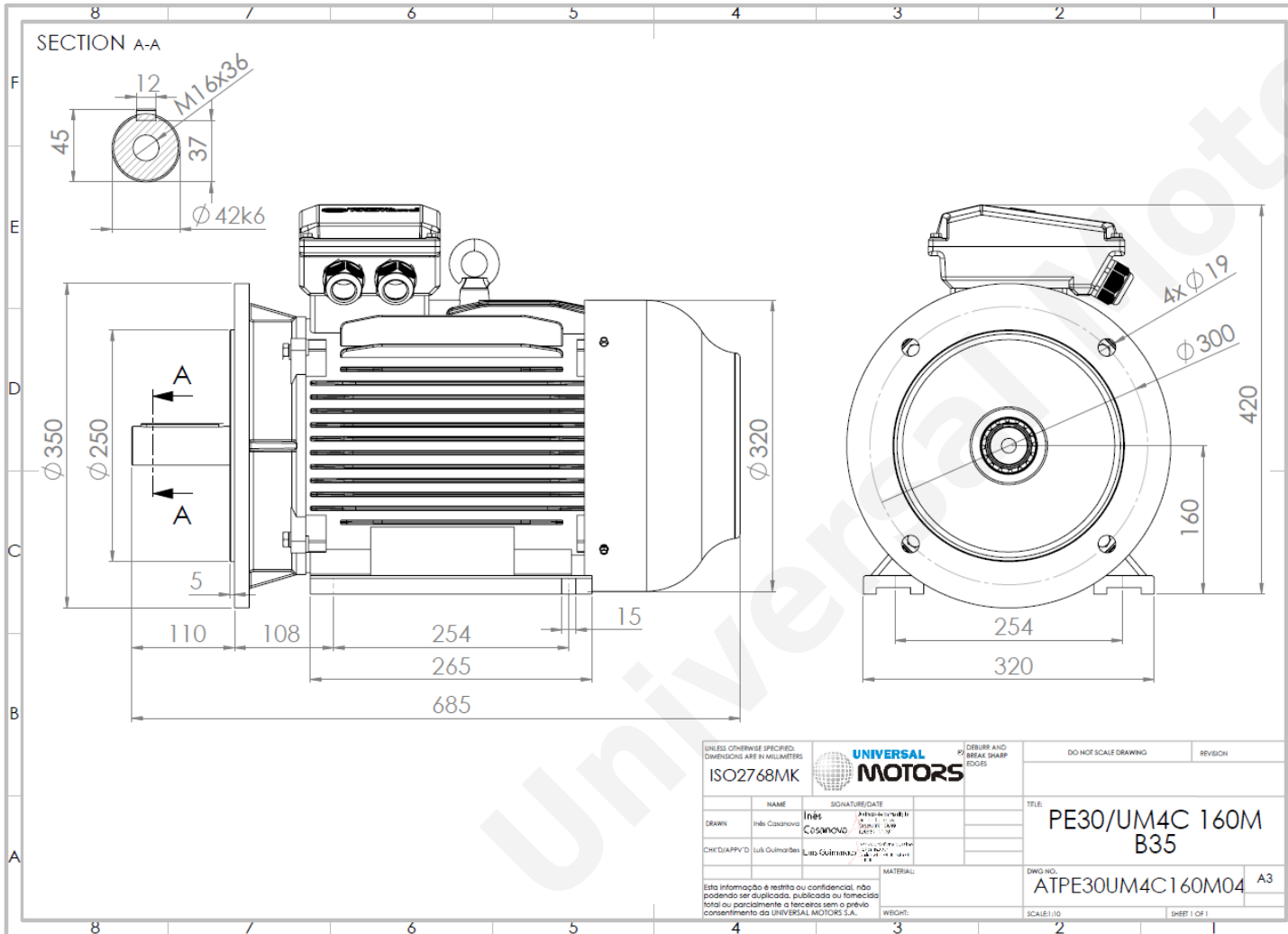

Motor type:	UM3C 160MX-8 IE3
Output:	5.5 kW / 7.5 Cv
Speed (min ⁻¹):	720 RPM
Voltage:	400 V
Frequency:	50 Hz
Current:	12.40 A
Power factor (Cos ϕ):	0.74
Poles:	8
Insulation class:	F
Temperature rise Class:	B
Efficiency 50%:	83.6 %
Efficiency 75%:	86.4 %
Efficiency 100%:	86.2 %
Torque:	73 N.m
Tstarting/Tnominal:	1.9
Istarting/Inominal:	6.0
Tmaximum/Tnominal:	2.0
Noise:	68 Db(A)
Weight:	117 Kg
Bearing DE:	6309 C3
Bearing NDE:	6309 C3

Regime - S1

Altitude - 1000m

Environment Temperature - 40°C

CONTACTS:

Universal Motors UK, Ltd
 Unit E2, Meltham Mills Industrial Estate, Meltham Mills Road, Meltham, Holmfirth
 West Yorkshire HD9 4AR, U.K.

Tel: +44(0) 1484 660 222

Fax: +44(0) 1484 660 333

Mail: enquiries@universalmotors-group.co.uk

* References applied only in the UK