

TECHNICAL DATA

Three Phase Electric Motors - Cast Iron Frame
 UM3C 225M-8 IE3
 22 kW / 30 Cv
 730 RPM

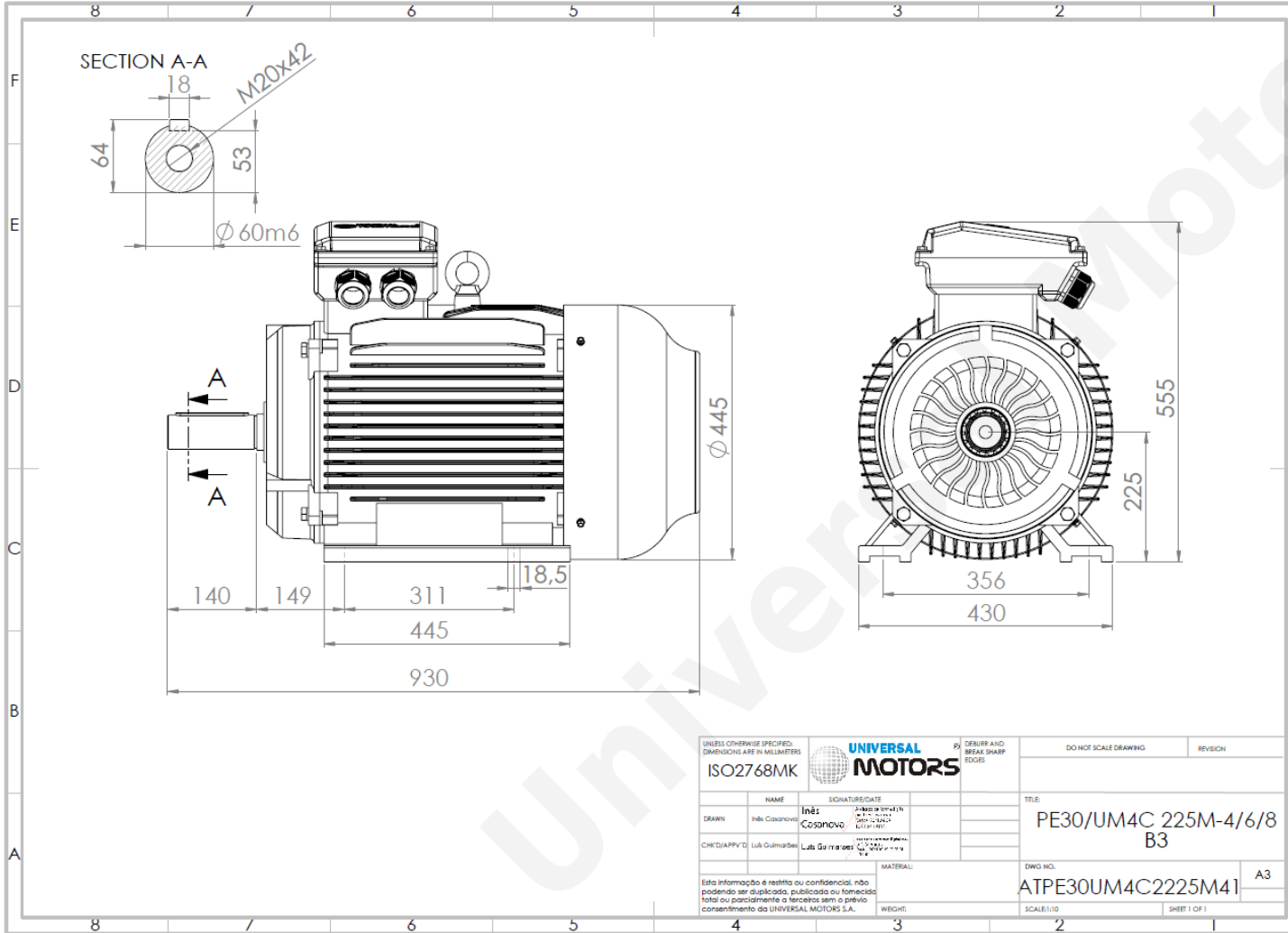

Motor type:	UM3C 225M-8 IE3
Output:	22 kW / 30 Cv
Speed (min ⁻¹):	730 RPM
Voltage:	400 V
Frequency:	50 Hz
Current:	44.9 A
Power factor (Cos Ø):	0.78
Poles:	8
Insulation class:	F
Temperature rise Class:	B
Efficiency 50%:	89.4 %
Efficiency 75%:	90.9 %
Efficiency 100%:	90.6 %
Torque:	287 N.m
Tstarting/Tnominal:	1.9
Istarting/Inominal:	6.6
Tmaximum/Tnominal:	2.0
Noise:	73 Db(A)
Weight:	319 Kg
Bearing DE:	6313 C3
Bearing NDE:	6313 C3

Regime - S1

Altitude - 1000m

Environment Temperature - 40°C

CONTACTS:

Universal Motors UK, Ltd
 Unit E2, Meltham Mills Industrial Estate, Meltham Mills Road, Meltham, Holmfirth
 West Yorkshire HD9 4AR, U.K

Tel: +44(0) 1484 660 222
 Fax: +44(0) 1484 660 333

Mail: enquiries@universalmotors-group.co.uk

* References applied only in the UK