

TECHNICAL DATA

Three Phase Electric Motors - Cast Iron Frame
UM3C 315M-8 IE3
75 kW / 100 Cv
735 RPM

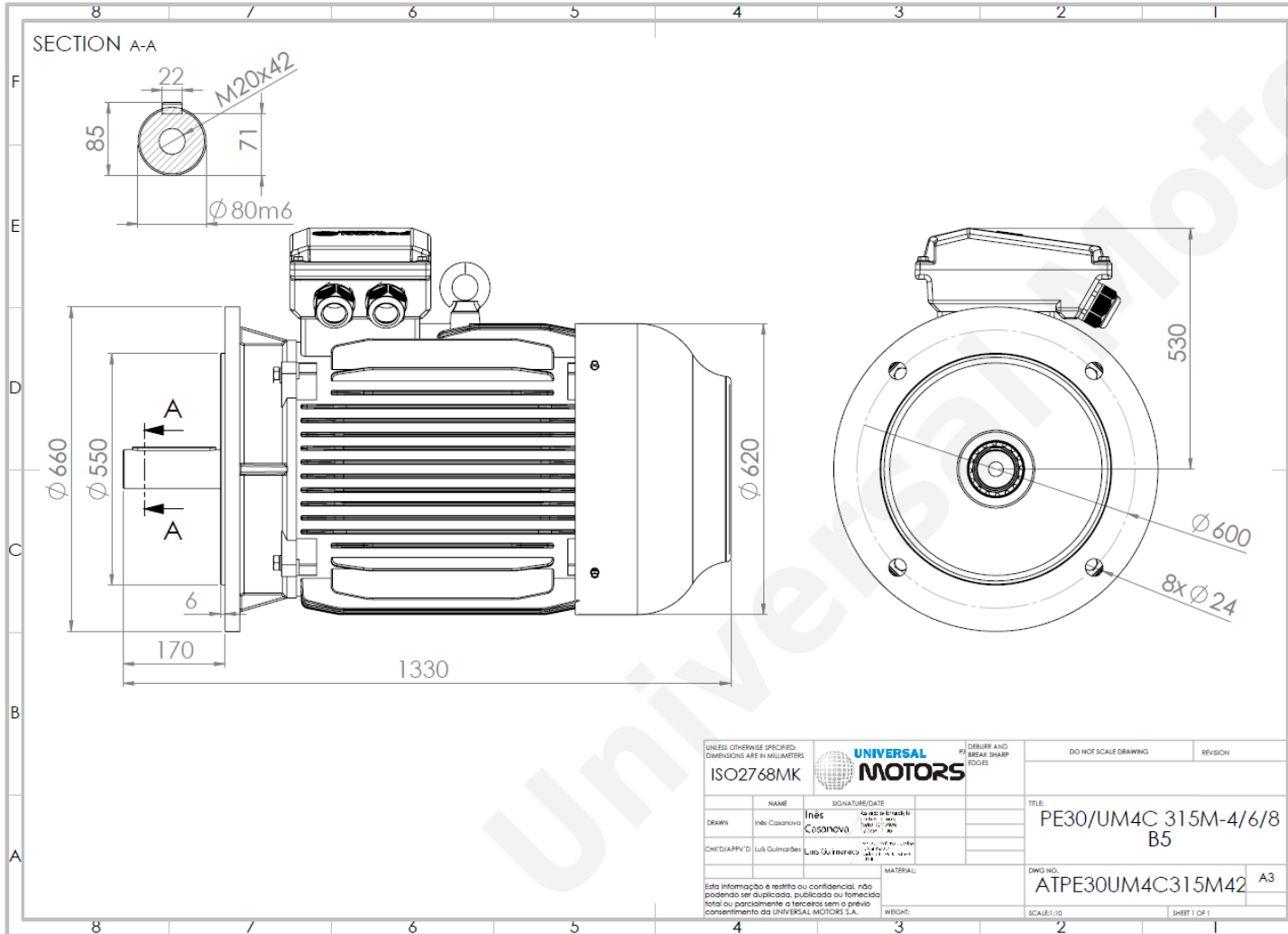

Motor type:	UM3C 315M-8 IE3
Output:	75 kW / 100 Cv
Speed (min ⁻¹):	735 RPM
Voltage:	400 V
Frequency:	50 Hz
Current:	143.6 A
Power factor (Cos Ø):	0.81
Poles:	8
Insulation class:	F
Temperature rise Class:	B
Efficiency 50%:	92.0 %
Efficiency 75%:	93.5 %
Efficiency 100%:	93.1 %
Torque:	972 N.m
Tstarting/Tnominal:	1.8
Istarting/Inominal:	6.2
Tmaximum/Tnominal:	2.0
Noise:	82 Db(A)
Weight:	1026 Kg
Bearing DE:	NU 319
Bearing NDE:	6319 C3

Regime - S1

Altitude - 1000m

Environment Temperature - 40°C

CONTACTS:

Universal Motors UK, Ltd
Unit E2, Meltham Mills Industrial Estate, Meltham Mills Road, Meltham, Holmfirth
West Yorkshire HD9 4AR, U.K

Tel: +44(0) 1484 660 222

Fax: +44(0) 1484 660 333

Mail: enquiries@universalmotors-group.co.uk

* References applied only in the UK