

# TECHNICAL DATA

Three Phase Electric Motors - Cast Iron Frame  
UM3C 225M-6 IE3  
30 kW / 40 Cv  
985 RPM

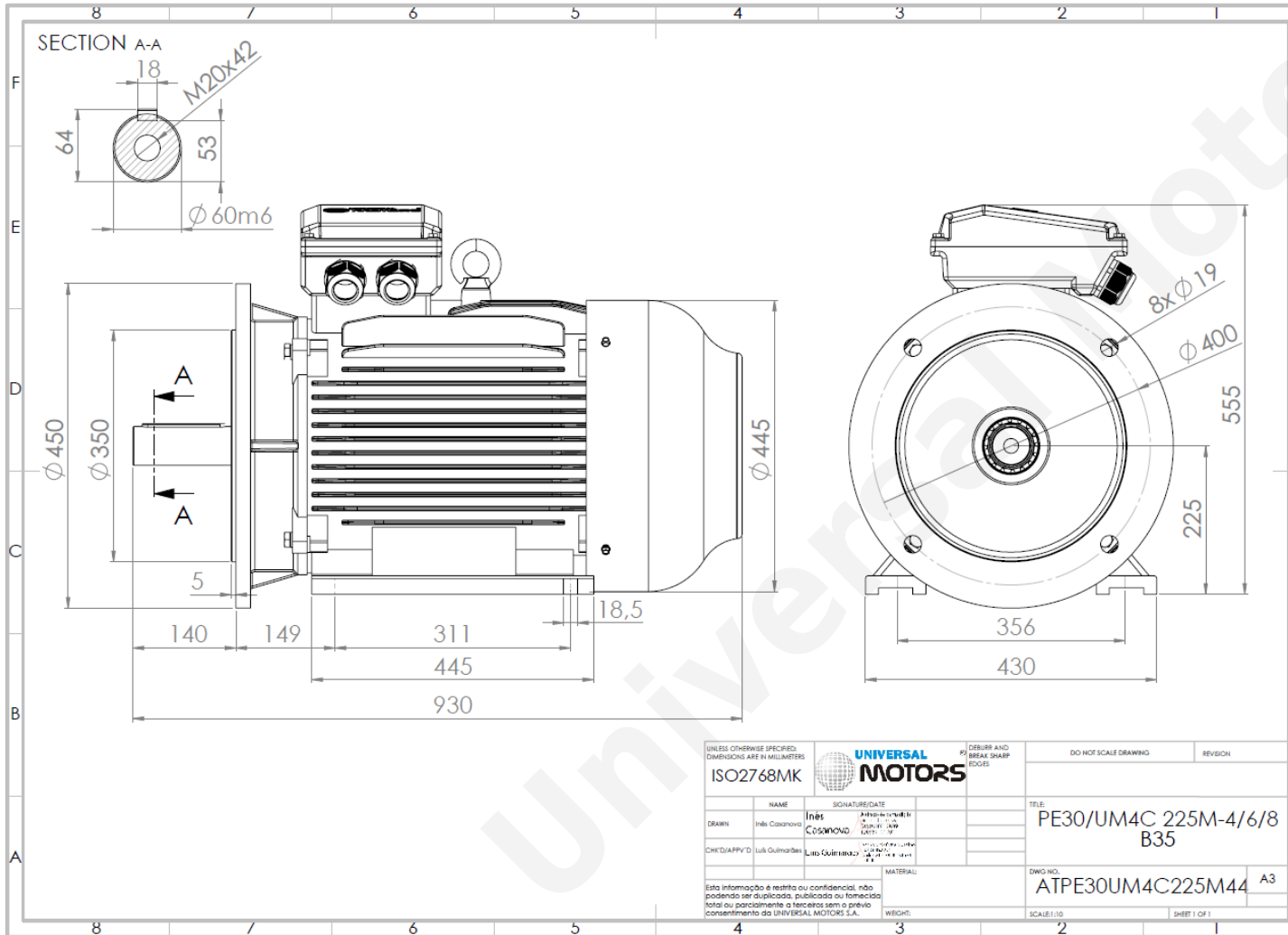

|                             |                        |
|-----------------------------|------------------------|
| Motor type:                 | <b>UM3C 225M-6 IE3</b> |
| Output:                     | <b>30 kW / 40 Cv</b>   |
| Speed (min <sup>-1</sup> ): | <b>985 RPM</b>         |
| Voltage:                    | <b>400 V</b>           |
| Frequency:                  | <b>50 Hz</b>           |
| Current:                    | <b>56.2 A</b>          |
| Power factor (Cos $\phi$ ): | <b>0.83</b>            |
| Poles:                      | <b>6</b>               |
| Insulation class:           | <b>F</b>               |
| Temperature rise Class:     | <b>B</b>               |
| Efficiency 50%:             | <b>92.2 %</b>          |
| Efficiency 75%:             | <b>93.2 %</b>          |
| Efficiency 100%:            | <b>92.9 %</b>          |
| Torque:                     | <b>291 N.m</b>         |
| Tstarting/Tnominal:         | <b>2.0</b>             |
| Istarting/Inominal:         | <b>6.9</b>             |
| Tmaximum/Tnominal:          | <b>2.1</b>             |
| Noise:                      | <b>74 Db(A)</b>        |
| Weight:                     | <b>392 Kg</b>          |
| Bearing DE:                 | <b>6313 C3</b>         |
| Bearing NDE:                | <b>6313 C3</b>         |

Regime - S1

Altitude - 1000m

Environment Temperature - 40°C

**CONTACTS:**

Universal Motors UK, Ltd  
Unit E2, Meltham Mills Industrial Estate, Meltham Mills Road, Meltham, Holmfirth  
West Yorkshire HD9 4AR, U.K

Tel: +44(0) 1484 660 222

Fax: +44(0) 1484 660 333

Mail: [enquiries@universalmotors-group.co.uk](mailto:enquiries@universalmotors-group.co.uk)

\* References applied only in the UK