

TECHNICAL DATA

Three Phase Electric Motors - Cast Iron Frame
 UM3C 200L-6 IE3
 18.5 kW / 25 Cv
 985 RPM

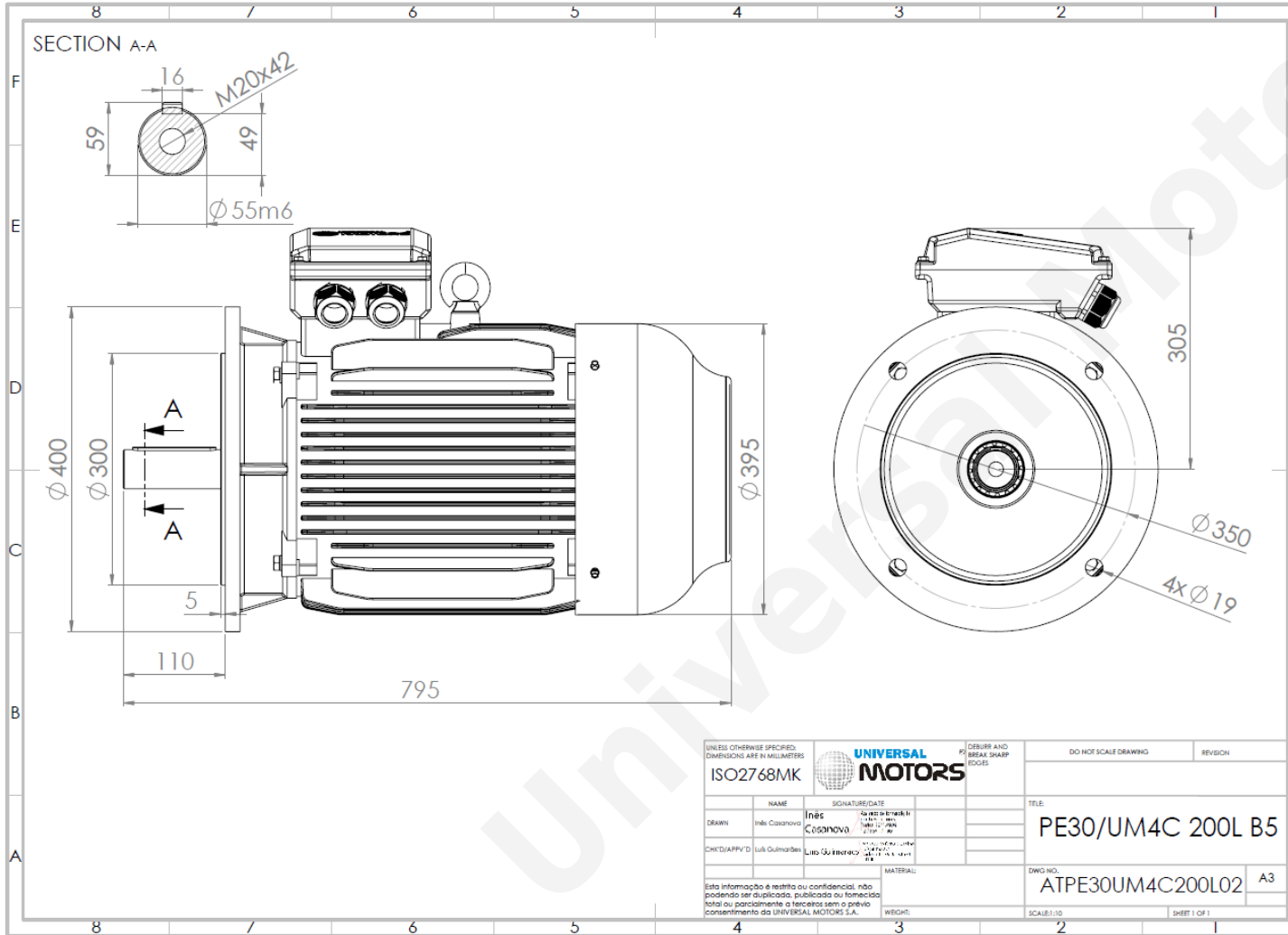

Motor type:	UM3C 200L-6 IE3
Output:	18.5 kW / 25 Cv
Speed (min ⁻¹):	985 RPM
Voltage:	400 V
Frequency:	50 Hz
Current:	36.0 A
Power factor (Cos Ø):	0.81
Poles:	6
Insulation class:	F
Temperature rise Class:	B
Efficiency 50%:	90.7 %
Efficiency 75%:	92.0 %
Efficiency 100%:	91.7 %
Torque:	179 N.m
Tstarting/Tnominal:	2.0
Istarting/Inominal:	7.3
Tmaximum/Tnominal:	2.1
Noise:	73 Db(A)
Weight:	260 Kg
Bearing DE:	6312 C3
Bearing NDE:	6312 C3

Regime - S1

Altitude - 1000m

Environment Temperature - 40°C

CONTACTS:

Universal Motors UK, Ltd
 Unit E2, Meltham Mills Industrial Estate, Meltham Mills Road, Meltham, Holmfirth
 West Yorkshire HD9 4AR, U.K

Tel: +44(0) 1484 660 222

Fax: +44(0) 1484 660 333

Mail: enquiries@universalmotors-group.co.uk

* References applied only in the UK