

TECHNICAL DATA

Three Phase Electric Motors - Aluminum Frame
 UM3A 160L-2 IE3
 18.5 kW / 25 Cv
 2940 RPM

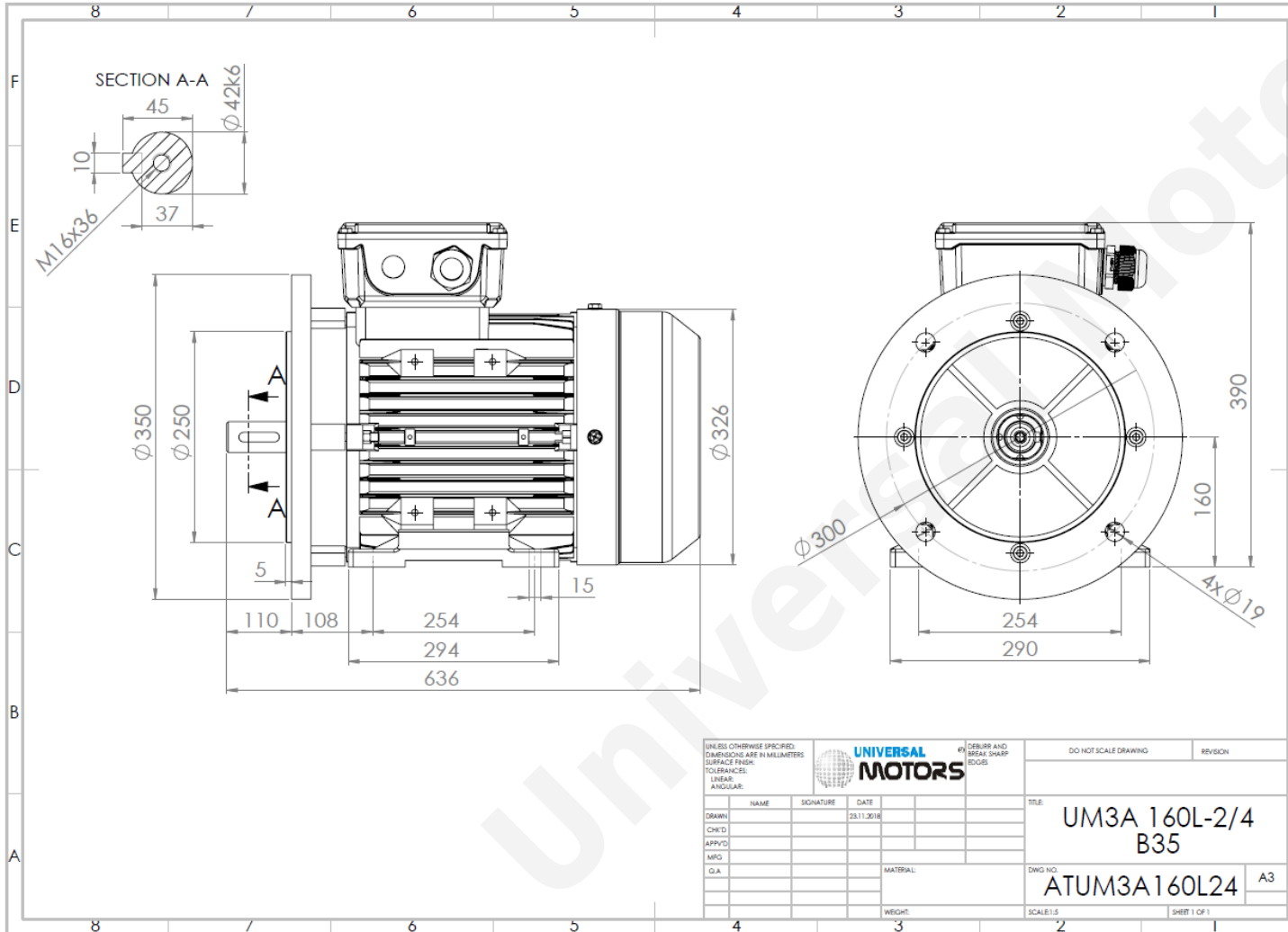

Motor type:	UM3A 160L-2 IE3
Output:	18.5 kW / 25 Cv
Speed (min ⁻¹):	2940 RPM
Voltage:	400 V
Frequency:	50 Hz
Current:	32.5 A
Power factor (Cos Ø):	0.89
Poles:	2
Insulation class:	F
Temperature rise Class:	B
Efficiency 50%:	90.6 %
Efficiency 75%:	91.5 %
Efficiency 100%:	92.4 %
Torque:	60.1 N.m
Tstarting/Tnominal:	2.2
Istarting/Inominal:	8.1
Tmaximum/Tnominal:	2.3
Noise:	87 Db(A)
Weight:	115 Kg
Bearing DE:	6309 2Z C3
Bearing NDE:	6309 2Z C3

Regime - S1

Altitude - 1000m

Environment Temperature - 40°C

CONTACTS:

Universal Motors UK, Ltd
 Unit E2, Meltham Mills Industrial Estate, Meltham Mills Road, Meltham, Holmfirth
 West Yorkshire HD9 4AR, U.K

Tel: +44(0) 1484 660 222

Fax: +44(0) 1484 660 333

Mail: enquiries@universalmotors-group.co.uk

* References applied only in the UK