

TECHNICAL DATA

Three Phase Electric Motors - Aluminum Frame
UM3A 160M-4
11 kW / 15 Cv
1460 RPM

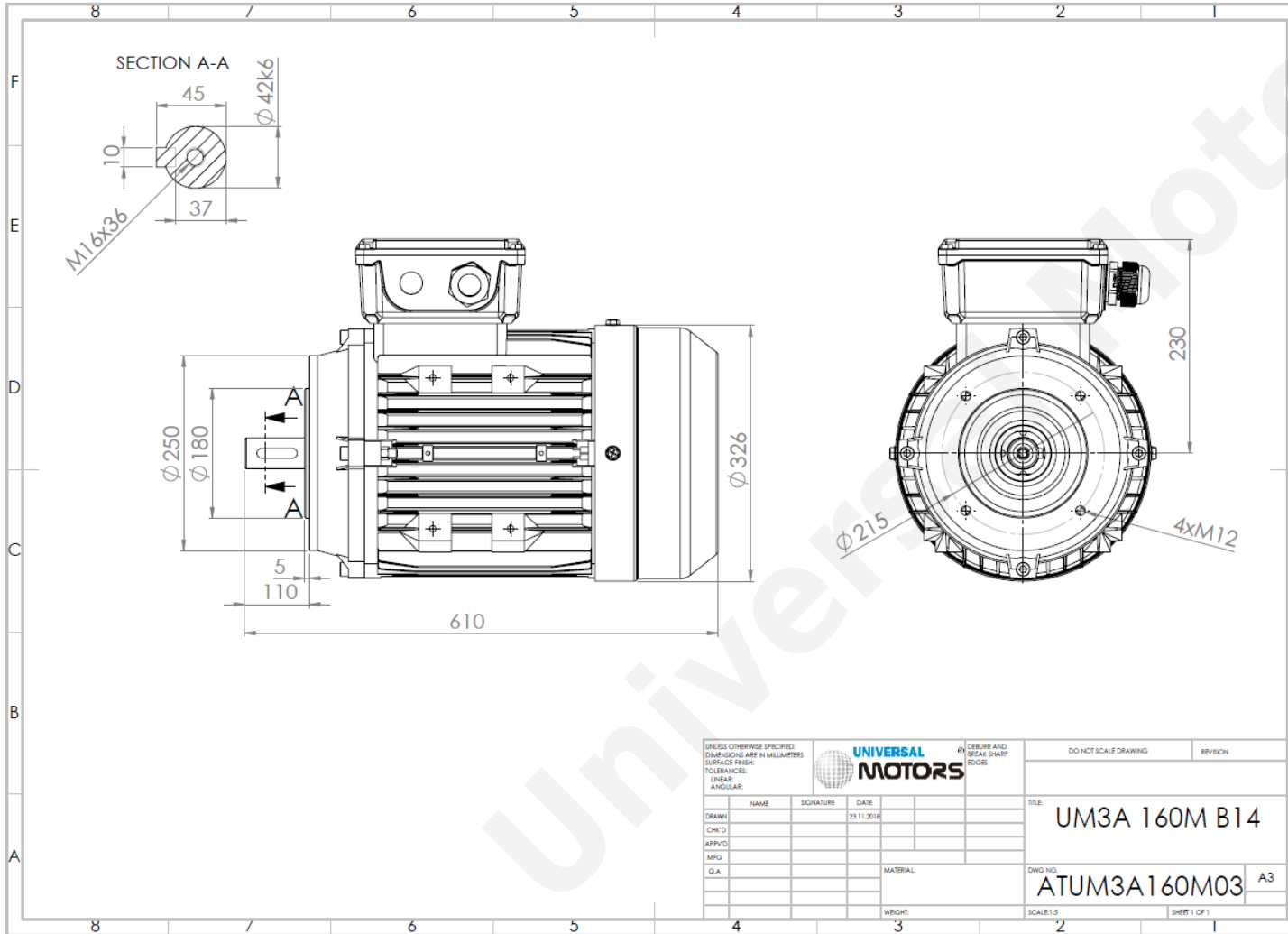

Motor type:	UM3A 160M-4
Output:	11 kW / 15 Cv
Speed (min ⁻¹):	1460 RPM
Voltage:	400 V
Frequency:	50 Hz
Current:	20.7 A
Power factor (Cos Ø):	0.84
Poles:	4
Insulation class:	F
Temperature rise Class:	B
Efficiency 50%:	89.6 %
Efficiency 75%:	90.5 %
Efficiency 100%:	91.4 %
Torque:	72.0 N.m
Tstarting/Tnominal:	2.2
Istarting/Inominal:	7.5
Tmaximum/Tnominal:	2.3
Noise:	77 Db(A)
Weight:	92 Kg
Bearing DE:	6309 2Z C3
Bearing NDE:	6309 2Z C3

Regime - S1

Altitude - 1000m

Environment Temperature - 40°C

CONTACTS:

ACDC Drives Ltd
Units 96 C & D, Blackpole Trading Estate, Blackpole Road,
Worcester, WR3 8TJ

Tel: +44(0) 1905 887 667
Mail: sales@acdcd rives.co.uk

* References applied only in the UK